

# Origins Spectral Interpretation Resource Identification Security-Regolith Explorer (OSIRIS-REx) Project

## OSIRIS-REx Thermal Emission Spectrometer (OTES) Uncalibrated / Calibrated Data Product Software Interface Specification

UA-SIS-9.4.4-304, Rev\_5.0

RELEASED

Revision – 5.0

May 21, 2019



## CM FOREWORD

This document is an OSIRIS-REx Project controlled document. Changes to this document require prior approval of the OSIRIS-REx Configuration Control Board (CCB) and Configuration Management Lead (CML). Proposed changes shall be submitted to the OSIRIS-REx Project CML, along with supportive material justifying the proposed change.

Questions or comments concerning this document should be addressed to:

SPOC Configuration Management Team

1415 N. 6<sup>th</sup> Avenue

Tucson, AZ 85705

Email: [spoc-cm@orex.lpl.arizona.edu](mailto:spoc-cm@orex.lpl.arizona.edu)



# OSIRIS-REx Project

## OTES Uncalibrated/ Calibrated Data

### Product SIS

#### SIGNATURE PAGE

*Prepared By:*

**Saadat Anwar** Saadat Anwar  
2019.05.21 16:10:31 -07'00'  
\_\_\_\_\_  
Saadat Anwar Date  
OTES Software Engineer

**M. Katherine Crombie** M. Katherine Crombie  
2019.05.21 16:10:19 -07'00'  
\_\_\_\_\_  
M. Katherine Crombie Date  
Indigo Information Services, LLC  
OSIRIS-REx PDS Lead

*Approved By:*

**Karl Harshman** Karl Harshman  
2019.05.22 18:11:03 -07'00'  
\_\_\_\_\_  
Karl Harshman Date  
SPOC Manager

**Vicky Hamilton** Vicky Hamilton  
2019.05.21 16:10:51 -07'00'  
\_\_\_\_\_  
Vicky Hamilton Date  
OTES Deputy Instrument Scientist

**Mike Fitzgibbon** Mike Fitzgibbon  
2019.05.22 18:10:50 -07'00'  
\_\_\_\_\_  
Mike Fitzgibbon Date  
SPOC Cal/Val Software Lead

**Nathan Mogk** Nathan Mogk  
2019.05.22 18:10:08 -07'00'  
\_\_\_\_\_  
Nathan Mogk Date  
SPOC Systems Engineer

DOCUMENT CHANGE LOG

Rev/ Version Level	Description of Change	Approved By	DATE DRAFT ISSUED (MM/DD/YYYY)	DATE REVIEW COMPLETED (MM/DD/YYYY)	VERSION RELEASE DATE (MM/DD/YYYY)
1.0	Initial Release				01/08/2015
2.0	Cover page updates  Remove GeoGen reference and include updated spatial processing information  Update L0 data product with expanded and corrected column fields  Typo and consistency fixes  Update applicable documents and versions  Refactor section 4.3.3 to add data volumes by phase  Added label information to section 4.3.4  Revisions after review	ECR-0024			05/04/2016
3.0	Update per Change Requests	CR-66, CR-234			05/23/2018
4.0	Update per Change Requests	CR-332, CR-339			01/24/2019
5.0	Update per Change Request	CR-433			05/13/2019

LIST OF TBDs/TBRs

SECTION ID	DESCRIPTION OF TBD/TBR	DATE OF RESOLUTION

TABLE OF CONTENTS

1 Purpose and Scope ..... 9

2 Applicable Documents and Constraints ..... 9

3 Relationships with Other Interfaces .....10

4 Data Product Characteristics and Environment .....11

    4.1 Instrument Overview .....11

        4.1.1 Observation Profile and Data Acquisition .....13

    4.2 Data Product Overview .....16

    4.3 Data Processing .....17

        4.3.1 Data Processing Level .....17

        4.3.2 Data Product Generation.....18

            4.3.2.1 Level-0 Raw Data and Level-1 Converted Data .....19

            4.3.2.2 Target Tagger .....20

            4.3.2.3 Level-1 Science and Level-2 Calibrated Spectra .....20

        4.3.3 Data Flow .....22

        4.3.4 Labeling and Identification .....24

    4.4 Standards Used in Generating Data Products .....26

        4.4.1 PDS Standards .....26

        4.4.2 Time Standards .....26

        4.4.3 Coordinate Systems .....26

        4.4.4 Data Storage Conventions .....27

    4.5 Data Validation.....27

5 Detailed Data Product Specifications.....27

    5.1 Data Product Structure and Organization .....27

    5.2 Data Format Descriptions .....29

        5.2.1 L0 Raw(eng) File Format .....29

        5.2.2 L0 Raw(science) File Format .....35

        5.2.3 L1 Converted(eng) File Format .....36

        5.2.4 L1 Converted(science) File Format .....42

        5.2.5 Geo File Format .....42

        5.2.6 L2 Calibrated Radiance File Format .....45

    5.3 Label and Header Descriptions.....46

6 Applicable Software.....46

    6.1 Utility Programs .....46

6.2	Applicable PDS Software Tools.....	47
6.3	Software Distribution and Update Procedures .....	47
7	Appendices.....	48
7.1	Glossary.....	48
7.2	Acronyms .....	48
7.3	Definitions of Data Processing Levels .....	50
7.4	Example PDS Labels.....	50

**LIST OF FIGURES**

Figure 1:	A notional OTES Observation Sequence (left) and Raw files produced during it (right).....	14
Figure 2:	A notional OTES Observation Sequence that completely spans Bennu. ....	15
Figure 3:	A notional OTES Observation Sequence that collects data from multiple areas of interest (shown in yellow) on Bennu's surface.....	16
Figure 4.	SPOC OTES Cal/Val data processing pipeline .....	23

**LIST OF TABLES**

Table 3-1:	Interface Relationships.....	10
Table 4-1:	OTES Instrument Parameters.....	12
Table 4-2:	OTES Observational profile.....	13
Table 4-3.	OTES Data Product Processing Levels .....	17
Table 4-4	OTES APID Assignment .....	19
Table 4-5.	Calibration Equation Coefficients .....	21
Table 4-6.	OTES Data Volume by Mission Phase .....	23
Table 4-7:	Instrument Abbreviations.....	25
Table 4-8:	OTES Data Product Type.....	26
Table 5-1.	OTES Elements in the Product_Observational:Observation_Area:Mission_Area of the .XML Label.....	29
Table 5-2.	OTES Elements in the Product_Observational:File_Area_Observational:Table_Binary:Record_Binary of the .XML label. Binary records are stored in MSB byte order. ....	29
Table 5-3.	Additional OTES Elements in the Product_Observational:Observation_Area:Mission_Area of the .XML Label for Raw(science) products .....	35

Table 5-4. Additional OTES Elements in the Product\_Observational:File\_Area\_Observational:Table\_Binary:Record\_Binary of the .XML label for Raw(science) products. The table is identical to the L0 Raw(eng) with the additional 89<sup>th</sup> field containing the interferogram. ....36

Table 5-5. Geo File format .....43

Table 5-6. OTES Elements in the Product\_Observational:Observation\_Area:Mission\_Area of the .XML Label for calibrated radiance products .....45

Table 5-7. OTES Elements in the Product\_Observational:File\_Area\_Observational of the .XML label for calibrated radiance products .....45

## 1 Purpose and Scope

The data products described by this Software Interface Specification (SIS) are the OSIRIS-REx Thermal Emission Spectrometer (OTES) raw, uncalibrated and calibrated data products. Science data products derived from the radiometrically-calibrated data are beyond the scope of this document. The OSIRIS-REx Science Processing and Operation Center (SPOC) located at the University of Arizona produces these data products and distributes them to both the OSIRIS-REx Science Team and the Planetary Data System (PDS). This SIS describes how the OTES data products are acquired by the instrument, processed, formatted, labeled, and uniquely identified. The document discusses standards used in generating the product and software that may be used to access the products. Finally, examples of the product labels are provided.

The purpose of this document is to provide users of the data products with a detailed description of the product and a description of how it was generated, including data sources and destinations. The document is intended to provide enough information to enable users to read and understand the data product. The users for whom this document is intended are the scientists who will analyze the data, including those associated with the project and those in the general planetary science community.

## 2 Applicable Documents and Constraints

This Data Product SIS is consistent with the following Planetary Data System Documents:

1. Planetary Data System Standards Reference, Version 1.7.0, September 22, 2016.
2. PDS4 Data Dictionary – Abridged – Version 1.7.0.0, March 17, 2016.
3. PDS4 Information Model Specification, V.1.7.0.0, March 17, 2016.

This Data Product SIS is consistent with, responsive to, or extended by the following OSIRIS-REx documents:

4. OSIRIS-REx Science Data Management Plan, UA-PLN-9.4.4-004.
5. OSIRIS-REx Science Processing and Operations Center and Planetary Data System Small Bodies Node Interface Control Document, UA-ICD-9.4.4-101, Rev 1.0, October 31, 2013.
6. P.R. Christensen et al. The OSIRIS-REx Thermal Emission Spectrometer (OTES) Instrument, Space Science Reviews, in press 2017.
7. SPOC – OTES Interface Control Document, UA-9.4.4-1006.
8. OSIRIS-REx Coordinate System for Bennu V2, January 13, 2016.

Finally, this SIS is meant to be consistent with the contract negotiated between the OSIRIS-REx Project and the Science Processing and Operations Center.

### 3 Relationships with Other Interfaces

Changes to the data products described in this SIS affect the following software, products or documents:

**Table 3-1: Interface Relationships**

Name	Type	Owner
SPOC Database Schema	Product	SPOC
OTES (L0) Raw Data	Product	OTES Team, ASU
OTES (L1) Converted Data	Product	OTES Team, ASU
OTES (L2) Calibrated Radiance Spectra	Product	OTES Team, ASU
OTES L0 Software	Software	OTES Team, ASU
OTES L2 Software	Software	OTES Team, ASU
Spectral Processing Software	Software	OSIRIS-REx Spectral Processing Working Group
OTES Cal/Val Process	Software	SPOC
SPOC Archive Packager	Software	SPOC
OSIRIS-REx Spectral Processing Software Interface Specification	Document	OSIRIS-REx Spectral Processing Working Group
OSIRIS-REx Science Data Management Plan	Document	Project

Changes to the following software, products, and documents will impact this SIS:

Name	Type	Owner
OTES User’s Guide	Document	OTES Team, ASU
OSIRIS-REx Design Reference Mission Plan	Document	Project
OSIRIS-REx SPOC – OTEs ICD	Document	SPOC
SPOC Database Handbook	Document	SPOC
SPOC Pipeline Design Document	Document	SPOC
SPOC Geometric Generation Design Document	Document	SPOC



Name	Type	Owner
OSIRIS-REx SPOC Detail Design Document	Document	SPOC

## 4 Data Product Characteristics and Environment

### 4.1 Instrument Overview

The OSIRIS-REx Thermal Emission Spectrometer (OTES) is a small infrared (4-50  $\mu\text{m}$ ) point spectrometer that acquires an interferogram every 2 seconds. Interferograms are processed on the ground and converted to infrared spectra. OTES uses space and internal calibration target views for calibration. OTES will map Bennu and the sample site from a distance of 7 to 0.5 km with 55 to 4 m resolution using spacecraft and asteroid motion.

OTES is a derivative of the MGS TES and MER Mini-TES spectrometers combining the Mini-TES interferometer and electronics with the TES 15-cm telescope and beamsplitter to achieve the science objectives. Four versions of this spectrometer have operated successfully in space for total mission duration of 23 years as of 2017.

The OTES instrument is a Michelson moving-mirror point interferometer with a single uncooled IR detector. Physical motion of spacecraft points the OTES instrument at various targets. When turned on, the OTES instrument produces data every two seconds. These data are instrument *engineering-only*, when OTES is in *idle* mode (i.e. not actively acquiring science data); or instrument *engineering+interferogram* when OTES is in *acquire* mode (i.e. actively acquiring science/calibration observations called looks). OTES will be in *acquire* mode in response to either a data acquisition command (*data-looks* or *space-looks*) or calibration command (*cal-looks*). Interferograms collected by OTES are roughly 1350 samples (16-bits/sample) each.

OTES instrument commands can be separated into two groups: ‘*look*’ (or observation) commands that generate interferograms, and the ‘*non-look*’ commands that do not. Command execution status, such as success or failure, is reported in the instrument telemetry. Before OTES science data are acquired, the instrument is powered on and run in *idle* mode for roughly one hour to allow the OTES to reach thermal equilibrium.

An *OTES Observation Sequence* consists of *data-looks* interspersed with *space-looks* and *cal-looks*. When possible, the *data-looks* are bracketed by a pair of *space-looks* and *cal-looks*. *Space-looks* require that the instrument has a clear view of space, with no detectable objects within  $20^1$  mrad of the OTES optical axis<sup>2</sup>. *Cal-looks* require that the instrument stare at its calibrated internal cone blackbody target. During normal operation, internal calibration

---

<sup>1</sup> Notional value, which may be adjusted during mission.

<sup>2</sup> In this regard, distant stars do not transmit sufficient infrared radiation to be considered interfering with the OTES FOV.

looks are acquired approximately every 10 minutes; and each set of space-looks and cal-looks is roughly 10 ICKS (collection intervals). The actual length of the *space-* and *cal-look* sequences as well as their frequency is determined by the instrument scientist and the instrument engineer based on the mission parameters.

Science and calibration data (*engineering+interferograms*) collected for a single ‘*look*’ command are contained in a single data file. For example, if both *data-* (Bennu) and *space-looks* are acquired as a result of a single acquisition command, then both are stored in a single data file. Similarly, the *cal-looks* acquired as a result of a single calibration command are also stored in a single data file. Any telemetry captured during *idle* periods is stored in *engineering* only files. The *looks* acquired during a single **OTES Observation Sequence** (defined above) are converted into radiance spectra by performing Discrete Fourier Transform (DFT). These spectra are then converted into calibrated radiance spectra using the OTES calibration software, which utilizes the bounding *space-* and *cal-looks*, as available. The OTES data calibration flow and algorithms are documented in the OTES Instrument paper. Salient instrument design parameters are tabulated in Table 4-1 for convenience.

**Table 4-1: OTES Instrument Parameters**

Attribute	Value
Spectral Sampling Interval (or Angular Resolution)	8.66 cm <sup>-1</sup>
Spectral Range	5.71 –> 100 μm (1750-100 cm <sup>-1</sup> )
Telescope Aperture	15.2 cm
Detectors	uncooled deuterated L -alanine doped triglycine sulfate (DLATGS) pyroelectric
Michelson Mirror Travel	±0.289 mm
Mirror Velocity (physical travel)	0.321 mm/sec
Laser Fringe Reference Wavelength	854 ± 2 nm
Interferometer Sample Rate	772 Hz
Field of View (FOV)	6.47 mrad in azimuth and 6.22 mrad in elevation
Number of Samples per Interferogram (nominal)	1350 ±3
Number of Bits per Sample of Interferogram	16
Cycle Time per Measurement (or ICK Duration)	1.8 s plus 0.2 s scan reversal time
Dimensions (width x depth x height)	37.49 x 28.91 x 52.19 cm
Mass	6.27 kg
Power	10.8 W average; 15.99 W peak
Operating Temperature Range	-10 to +40 °C
Operating Temperature Range – Nominal Performance	+10 to 40 °C
Non-Operating Temperature Range	-15 to +45 °C

### 4.1.1 Observation Profile and Data Acquisition

Each instrument aboard OSIRIS-REx has specific scientific objectives in support of the overall mission objective of collecting and returning to Earth a pristine sample of the asteroid Bennu. Instrument specific observation campaigns have been outlined for each phase of the mission to support sample site selection and overall Bennu characterization. Table 4-2 below outlines the OTES observational campaigns.

Table 4-2: OTES Observational profile

Mission Phase	Observation Campaign Description
<i>Outbound Cruise</i>	Instrument Checkout
	Earth-Moon Flyby Observations
<i>Approach</i>	Instrument Checkout
	Approach Point Source Observations
<i>Preliminary Survey</i>	No observations planned
<i>Orbit A (1.5km)</i>	No observations planned
<i>Detailed Survey</i>	Global Observations from 7 times of day
<i>Orbital B (1.0km)</i>	Potential Sample Site Specific Observations
<i>Reconnaissance</i>	Sample Site Observations
<i>TAG-Rehearsal</i>	Sample Rehearsal Observations
<i>Sample Collection</i>	Sample Collection Observations

As mentioned before, the OTES instrument has two commands that produce interferogram (or *look*) data. These include the data acquisition command (*OTE\_ACQ*) and the calibration command (*OTE\_CAL*). Each of these commands is capable of collecting a sequence of observations (or *looks*). The sequence of observations collected by one such command is stored in one file, which includes the interferogram and the instrument engineering. Engineering data acquired during idling is stored in separate files (e.g. each gap between subsequent look commands could be stored in a file of its own).

Figure 1 illustrates a single OTES observation sequence, the commands executed, and the data products generated. Note the line lengths shown in the key to the right of the figure. The line lengths indicate the type of *look* being acquired.

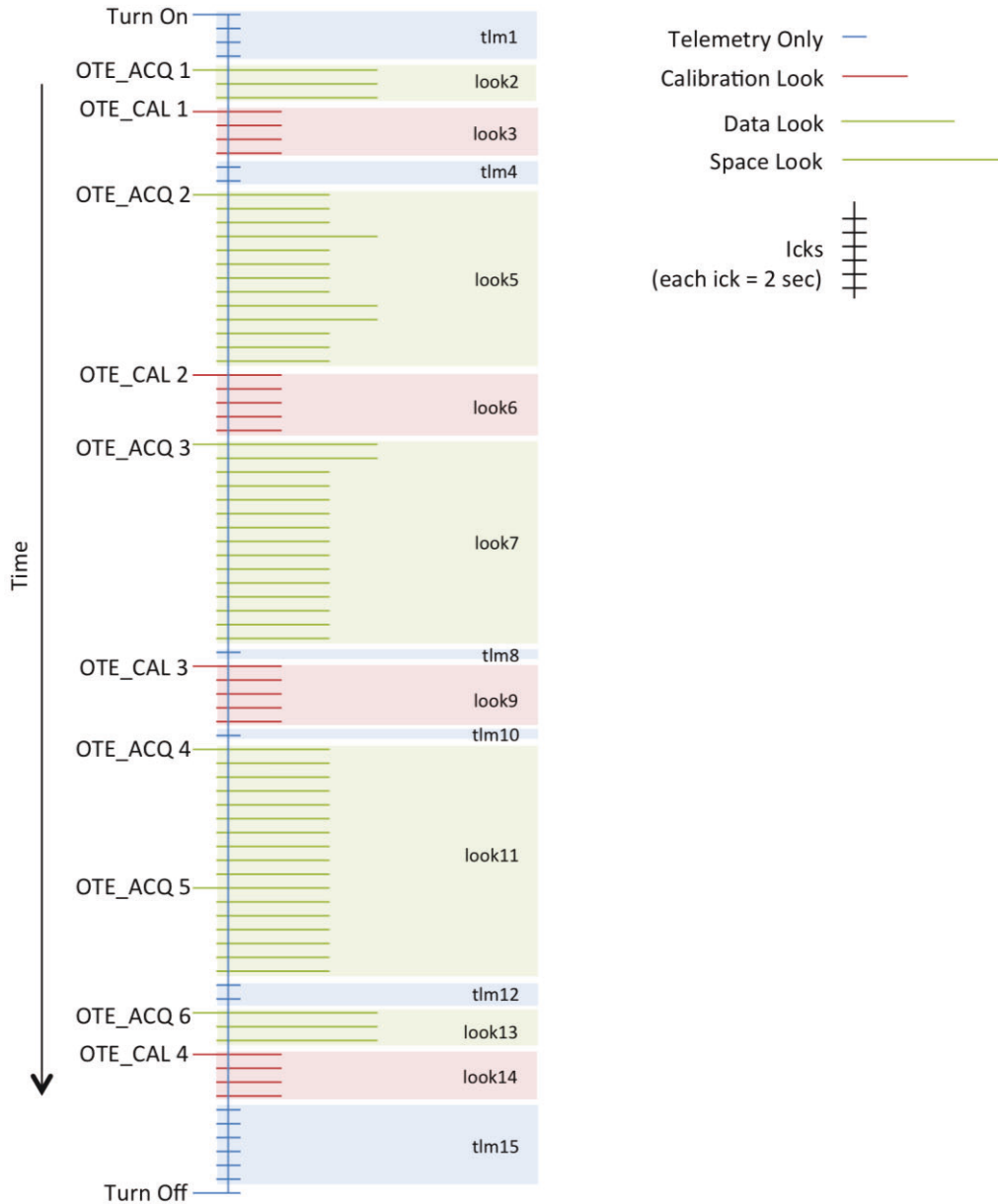

**Figure 1:** A notional OTES Observation Sequence (left) and Raw files produced during it (right).

Tick marks (on left) represent time in two-second intervals (or ICKs). Shortest lines represent idle cycles where OTES produces engineering only and no command is executing. Longer lines in the order of length represent

calibration-looks, data-looks, and space-looks, respectively. Each ACQ and CAL command produces a sequence of observations/looks. Looks from a single ACQ/CAL command are stored in one file. For example, OTE\_ACQ 2 produces a sequence of 3x data-looks, 1x space-look, 4x data-looks, 2x space-looks, and 3x data-looks. OTE\_CAL 2 produces a sequence of 5x cal-looks; and the instrument idles for one ICK between OTE\_ACQ 3 and OTE\_CAL 3.

Here files *look2*, *look3*, *look5*, *look6*, *look7*, *look9*, *look11*, *look13*, *look14* will be processed simultaneously and converted into a single L2 calibrated data file containing calibrated spectra for the entire observation sequence.

Figure 2 and Figure 3 give a notional idea of two different kinds of OTES Observation Sequences at different mission phases. For optimal calibration, data from all observations/looks shown in Figure 2 must be calibrated as a unit. Similarly, (for optimal calibration) data from all observations/looks shown in Figure 3 must be calibrated as a unit.

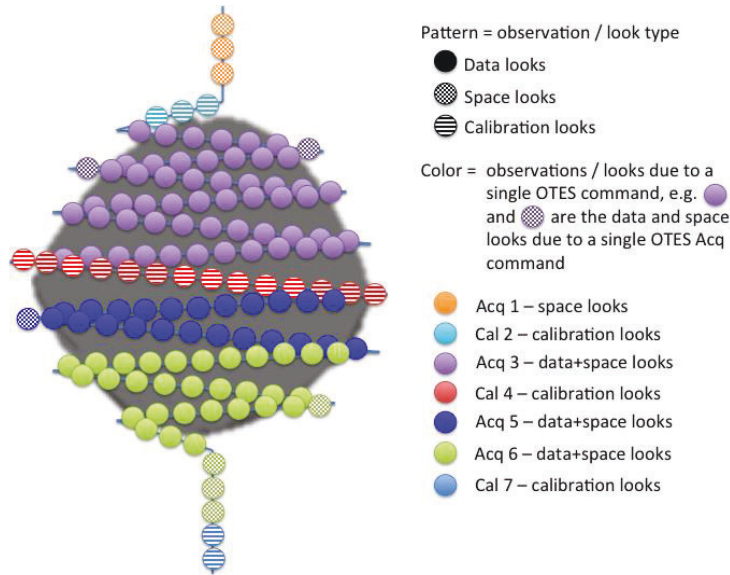

**Figure 2:** A notional OTES Observation Sequence that completely spans Bennu.

The sequence consists of seven acquisition and calibration commands, each identified by its own color. Patterns within the color identify whether an observation / look is a data, space, or calibration looks. Note that there is no distinction between off-Bennu and on-Bennu looks acquired due to a calibration (OTE\_CAL) command, while off-Bennu and on-Bennu looks due to an acquisition (OTE\_ACQ) command are bifurcated into space-looks and data-looks.

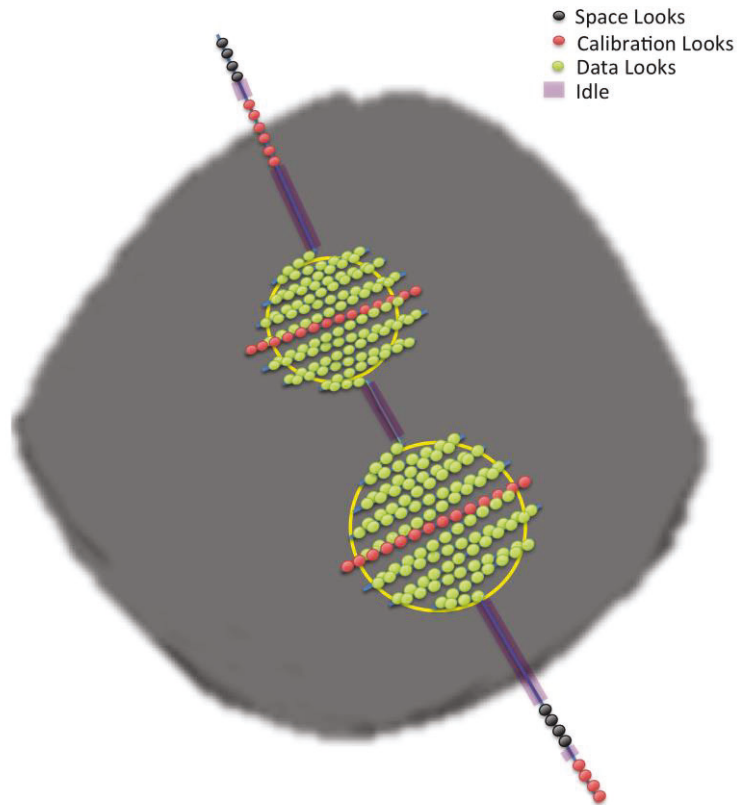

**Figure 3:** A notional OTES Observation Sequence that collects data from multiple areas of interest (shown in yellow) on Bennu's surface.

The sequence is bracketed by a space-look + calibration-look pair (shown in black and red respectively) on both ends.

## 4.2 Data Product Overview

The basic unit of data from the OTES instrument is a record consisting of either engineering words only (*idle* data), or engineering plus interferograms (*look* data). On the ground, records from an *OTES Observation Sequence* are collected into a sequence of raw files made up of *engineering-only* or *engineering+interferogram* data. The *engineering-only* data are reformatted into PDS standard format files and are processed to convert Digital Numbers (DN) to physical units (e.g. temperature, voltages and currents). The *engineering+interferogram (look)* data are reformatted into PDS standard files. The *look* data files for the entire *OTES Observation Sequence* are processed together and converted to physical units and then calibrated into radiance spectra. The calibrated spectra are stored in calibrated spectra files following the PDS standards.

Within each file, data is organized as fixed length records in a time sequential (or chronological) order. A complete description of the various files is given in Detailed Data Product Specifications.

### 4.3 Data Processing

All OSIRIS-REx mission science data processing is performed at the University of Arizona Science Processing and Operations Center (SPOC). OTES science and engineering telemetry are received by the SPOC via the Lockheed Martin Mission Support Area (MSA). OTES raw telemetry data are reconstructed (OREx Level 0), DNs converted to physical units (OREx Level 1) and stored in the SPOC data repository. OTES science data (along with its associated engineering) are reconstructed, converted, and packaged as observation sequence files and stored in the SPOC data repository. Observation sequence files are retrieved from the data repository and fed into the OTES-specific data processing pipeline. The pipeline produces calibrated OTES spectra (OREx Level 2). Generally, data are stored in a binary table format. Production rates of calibrated spectra vary over the course of the mission and are dependent on observing campaigns during specific mission phases. Individual file sizes based on the current Design Reference Mission (DRM) are as follows: OTES Raw(science) data files are approximately 0.83 MB; OTES Raw(eng) files are approximately 2 MB (assuming storage into fixed size chunks); converted files are similar in size to raw files; and Calibrated Spectra data files are approximately 43 MB. Specific file sizes will vary dependent on the number of records in each sequence, and how long the instrument idles, which is driven by the mission DRM.

#### 4.3.1 Data Processing Level

The OTES data products comply with NASA processing level standards as shown in Table 4-3. OTES data products are derived from the previous level product. Correlation to NASA and CODMAC data processing levels and definitions can be found in Appendix 7.3. Calibration file data processing levels are not discussed, as calibration files require special production techniques.

**Table 4-3. OTES Data Product Processing Levels**

OTES Product	NASA Product Level	OSIRIS-REx Processing Level	Description
N/A	Packet data	N/A	OTES IDP packets received on the ground containing either <i>engineering</i> or <i>engineering+interferogram</i> data
Raw (eng)	Level-0	L0	Instrument engineering records in time order with voltage and temperature DN values. Invalid packets are discarded.
Raw (science)	Level-0	L0	Instrument <i>engineering+interferogram</i> records in time order with voltage and temperature DN values. Invalid packets are discarded.
Converted (eng)	Level-1	L1	Instrument engineering records in time order with voltage and temperature DN values



OTES Product	NASA Product Level	OSIRIS-REx Processing Level	Description
			converted into voltages and temperatures. Invalid packets are discarded.
Converted (science)	Level-1	L1	Instrument <i>engineering+interferogram</i> records in time order converted into voltages and temperatures.
Calibrated Spectra	Level-2	L2	Level-1 Converted(science) data in time order that has been calibrated and packaged with needed ancillary and auxiliary data. Auxiliary data includes the (space and internal-calibration target) calibration records.

### 4.3.2 Data Product Generation

The OTES Raw and Converted files will be generated by the SPOC at University of Arizona from the downlinked OTES spacecraft telemetry. The Raw products will contain raw, uncalibrated data, formatted according to the Raw format defined in this SIS. The Converted products will contain DN to physical unit converted uncalibrated data, formatted according to the Converted format described in this SIS. New versions of the products will be identified using a version identifier in the filename, as indicated in Section 4.3.4, and by the *Version\_Id* field in the PDS label. Spatial information for each spectrum is generated by the SPOC and stored in the database and as GeoFiles (described in Section 5). To produce the level-2 data, the SPOC will be responsible for populating the needed input files with appropriate data, including spatial information, providing uplinked command descriptions (as needed), and the location of files to the ASU-provided calibration pipeline software. On successful completion through the OTES calibration pipeline software, the SPOC will be responsible for inserting the output file data into the SPOC Data Repository. In case of errors, any messages produced as well as the error file will be saved for further diagnosis by the OTES engineers.

Calibrated Spectra will be automatically produced by the calibration pipeline software as soon as all Raw(science) data for the current OTES Observation Sequence (identified using use time gaps in telemetry as indicators of sequence boundaries) have been received and processed and their associated geometry are available. The SPOC will monitor the records being downlinked and correlate them with the uplinked commands in order to ensure that all commanded data has been accounted for.

New versions of Calibrated Spectra will be generated should the raw data, the geometry, the calibration algorithm, or the calibration software components change. Changes to the calibration algorithm and software components will be rare events. It is more likely that an update to geometry will cause re-processing. New versions of the Calibrated Spectra will be



identified by incrementing the version identifiers (filename version and PDS label Version\_Id) in the data. All versions of the data products are retained in the SPOC repository for reference, however only certified valid products are released to the PDS. Should products need to be updated in the archive, the new certified valid products will replace the older (deprecated) versions.

#### 4.3.2.1 Level-0 Raw Data and Level-1 Converted Data

Data processing begins with the ingestion of spacecraft telemetry into the SPOC database. The SPOC will receive *engineering-only* data and look-data on separate APIDs (Application Process Identifier, see Table 4-4). The APIDs are used within the spacecraft telemetry as identifiers for different types of data packets. The SPOC examines the telemetry, sorts on APID, strips the telemetry headers and stacks the resulting instrument data packets (IDPs) into files, such that there is one file for each data acquisition sequence and calibration sequence. Telemetry IDP packets for a single OTES sequence acquired during idling regions between acquisition and calibration sequences are stored in record chunks of arbitrary size such that a single chunk does not span more than one sequence. The stacked files will be padded with zeros in the regions where data dropouts occur<sup>3</sup>.

Table 4-4 OTES APID Assignment

APID	Description
85	OTES Engineering
86	OTES Science
87	OTES Unrecognized

The SPOC digest process then operates on each of these stacked binary files containing raw OTES (IDP) packets. These Raw L0 files are stored in the SPOC database. Storage of a new Raw L0 file as records in the SPOC database triggers the conversion of raw DN values to physical units where applicable and calculation of observation spatial and geometric information for each data record, thus creating the Converted (L1) engineering data products. Converted (L1) science products are discussed in the next section.

The SPOC OTES Pipeline monitors the SPOC Data Repository [using time-out mechanism] to determine when all data for an **OTES Observation Sequence** have been received. At this point, the monitor invokes the SPOC Pipeline for OTES calibration processing. Observations are denoted by periods of instrument activity and data gathering and are separated by periods of instrument inactivity.

---

<sup>3</sup> In this regard, only data dropouts that could result in partial OTES packets are of significance as they could cause head of one packet attached to the tail of another packet to create a normal looking packet.

### 4.3.2.2 Target Tagger

The geometry and internal calibration flag of each record will identify it as one of three types of targets relevant for calibration. These are space-looks, calibration-looks, and data-looks.

They are identified in the following manner:

1. A record in which the internal calibration flag is closed is an *internal calibration-look* record. The calibration flag is closed if the “Cal flag status” bit is zero in the “config\_status” telemetry field.
2. A record is a *space calibration* record if the calibration flag is open and the OTES FOV is clear of occlusions and interference from Bennu (and other nearby visible objects). The FOV is clear of interference from Bennu if the angle between the OTES optical axis and Bennu is roughly greater than  $20^4$  mrad. The number of OTES FOV diameters between the optical axis of OTES and Bennu’s limb is given in the label attribute `fov_diameter_distance` (FITS `otesfov` keyword) in the spatial information record, as computed by the SPOC spatial generation software, corresponding to the OTES record, where a spatial record is linked to a Raw(science) file record by the unique SCLK field.
3. A record that is neither an internal calibration record nor a space-look record is a data-look record.
4. Look type is recorded in the spatial information record in the final column of the data table. The data table column is described by the “look\_type” label attribute.

### 4.3.2.3 Level-1 Science and Level-2 Calibrated Spectra

The Cal/Val pipeline (aka OTES calibration pipeline) uses a function to query the SPOC database for L1 observation sequence products ready to be processed. For OTES, the function looks for packets identified with APIDs 85 or 86 that have not been processed. The query uses the `idp_seconds` field to determine the products and then validates that there are not excessive gaps between `idp_transaction_counter` increments and that at least one record has science data and has not been processed. The looks are separated by their `acquisition_id` and only include records with science data.

The SPOC Pipeline Controller retrieves the Raw(science) files and their associated observation spatial and geometric information for a single **OTES Observation Sequence** as inputs from the SPOC database. Spatial and geometric information were calculated by the digest process after insertion of the Raw products into the database. The geometry contains the geometry information for each OTES individual collection interval in the sequence (or *look*) needed for optimal calibration of OTES data. The OTES calibration pipeline transforms the interferogram into a voltage spectrum. The transformation is done by performing Discrete Fourier Transform (DFT) on the raw interferogram. Note that a raw interferogram will have 1414 points, which is the buffer size of the OTES instrument. The buffer is large compared to the actual number of points collected in the interferogram ( $\sim 1350 \pm 5$ ). To compensate for this variation the raw interferogram is padded with zeros to a value of 1360. The data are then saved to the data repository as the L1 Converted(science) product. Voltage interferogram conversion coefficients can be found at the end of OTES Engineering Dictionary (`otes_eng_dic.pdf`) located in the documents collection of this archive.

---

<sup>4</sup> Notional value that may be updated during the mission.

The Converted(science) product is calibrated using the following equation (Christensen et al., 2018, equation 18):

$$\epsilon_{scene} B_{scene} = \left( \frac{V_{scene} - V_{space}}{V_{cal} - V_{space}} \right) \left( \frac{\epsilon_{cal} B_{cal} \rho_{flag} + \epsilon_{flag} B_{flag} - (\epsilon_{primary} B_{primary} \rho_{secondary} + \epsilon_{secondary} B_{secondary})}{\tau_{fore}} - \epsilon_{space} B_{space} \right) + \epsilon_{space} B_{space}$$

Terms in this equation are listed in Table 4-5. Calibration Equation Coefficients.

**Table 4-5. Calibration Equation Coefficients**

Equation Term	Value, Data Source or Definition
$\epsilon_{scene} B_{scene}$	Radiance of the scene
$V_{scene}$	Voltage value of the scene, which is the Fourier transform value of the L1 interferogram.
$V_{space}$	Voltage value of space, which is the Fourier transform value of the L1 interferogram.
$V_{cal}$	Voltage value of the cal, which is the Fourier transform value of the L1 interferogram.
$\epsilon_{cal}$	Emissivity of the calibration target vs. wavenumber (currently all 1.0, not delivered to PDS. If a change is made, it will be noted in delivery release notes.)
$B_{cal}$	The black body radiation of the calibration target from the associated engineering data (Table 5-2, Field Num 70)
$\rho_{flag}$	0.998
$B_{flag}$	The black body radiation of the calibration target flag from associated engineering data (Table 5-2, Field Num 71)
$\epsilon_{flag}$	0.002
$\epsilon_{primary}$	0.002
$B_{primary}$	The black body radiation of the primary mirror from associated engineering data (Table 5-2, Field Num 66-67)
$\rho_{secondary}$	0.998
$\epsilon_{secondary}$	0.002
$B_{secondary}$	The black body radiation of the secondary mirror from associated engineering data (Table 5-2, Field Num 68-69)
$\tau_{fore}$	0.996004 (= 0.998^2)
$\epsilon_{space}$	1.00000

Equation Term	Value, Data Source or Definition
Bspace	Black body spectrum at T=3 K

The resulting data and associated telemetry are stored in an OTES Calibrated Spectra (L2) file, which is placed back into the SPOC database.

Processing log messages (including error messages) generated during data processing are captured by the SPOC Pipeline Controller into log files. The SPOC Controller associates these log files with the target data products. The log files will be used by the OTES engineers for diagnosis in case of a processing failure but will not be archived.

### 4.3.3 Data Flow

OTES raw and calibrated data products are built up in sequential data processing steps addressing specific corrections or calibrations. All data products are built from raw telemetry ingested into the SPOC data repository system. The OTES calibration pipeline queries the SPOC data repository for the raw telemetry, science and ancillary data. Figure 4 illustrates the SPOC OTES Cal/Val pipeline data flow. Calibrated data products generated by the OTES calibration pipeline are returned to the SPOC data repository for storage. The OSIRIS-REx Instrument and Science Teams access data products in the data repository through a query tool.

Figure 4. SPOC OTES Cal/Val data processing pipeline

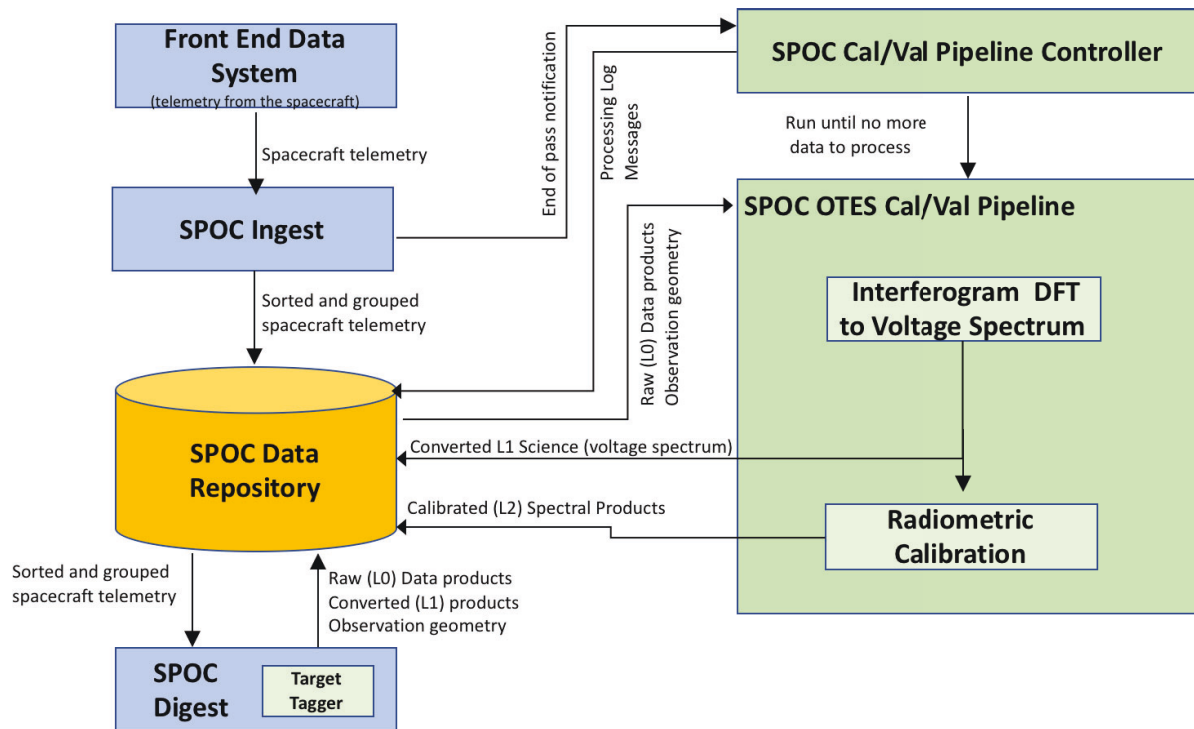

The table below shows the expected OTES data collection by mission phase. The number of expected individual collection intervals (ICKs) is specified as well as the expected data volume of the processed data products. Level-0 science data product volume is based on the per ICK data volume of 11555-bytes, Level-0 engineering data product volume is based on the per collection data volume of 178-bytes, assuming an equivalent number of engineering only collections as science collections. Level-1 engineering data product volume is based on the per collection data volume of 242-bytes and science is based on per ICK data volume of 11555-bytes. Level-2 science data product volume is based on the per ICK data volume of 2811-bytes.

Table 4-6. OTES Data Volume by Mission Phase

Mission Phase	Launch	Cruise	Approach	Prelim Survey	Orbit A	Detailed Survey	Orbit B	Recon	TAG Rehear	Sample Collection
# ICKs	900	3660	8840	0	0	72450	611100	9900	1470	1202
Raw(eng) MB	0.2	0.6	1.5	0.0	0.0	12.3	103.7	1.7	0.2	0.2
Raw(science) MB	9.9	9.9	9.9	9.9	9.9	9.9	9.9	9.9	9.9	9.9
Converted(eng) MB	0.2	0.2	0.2	0.2	0.2	0.2	0.2	0.2	0.2	0.2

Mission Phase	Launch	Cruise	Approach	Prelim Survey	Orbit A	Detailed Survey	Orbit B	Recon	TAG Rehear	Sample Collection
Converted(science) MB	9.9	40.3	97.4	0.0	0.0	798.4	6734.1	109.1	16.2	13.2
Cal Sci MB	2.4	9.8	23.7	0.0	0.0	194.2	1638.2	26.5	3.9	3.2

#### 4.3.4 Labeling and Identification

All OTES products consist of a PDS4-compliant detached XML label that describes the content and format of the associated data files. These labels describe the content and format of the associated data product. Labels and products are associated by file name with the label having the same name as the data product except that the label file has an .xml extension.

Labels are constructed with the PDS4 Product Class, Product\_Observational sub-class. The Product\_Observational sub-class describes a set of information objects produced by an observing system. A hierarchical description of the contents of Product\_Observational products is

##### Product\_Observational

Identification\_Area - attributes that identify and name an object.

Logical\_Identifier – unique identifier of product in PDS system

Version\_ID - version of product

Title - Name of file

Information\_model\_version - version of PDS4 information model used to create product

Product\_Class - attribute provides the name of the product class (Product\_Observational)

Modification\_History - attributes describing changes in data product

Observation\_Area - attributes that provide information about the circumstances under which the data were collected.

Time\_Coordinates - time attributes of data product

Primary\_Results\_Summary - high-level description of the types of products included in the collection or bundle

Investigation\_Area - mission, observing campaign or other coordinated, large-scale data acquisition attributes

Observing\_System - observing system (instrument) attributes

Target\_Identification - observation target attributes

Mission\_Area - mission specific attributes needed to describe data product

File\_Area\_Observational - describes a file and one or more tagged\_data\_objects contained within.

File - identifies the file that contains one or more data objects

Table\_Binary - defines a simple binary table.

Information in the preceding paragraphs was distilled from the PDS4 Information Model provided by PDS. Additional information on product labels can be found at <https://pds.nasa.gov/pds4/about/index.shtml>.

OSIRIS-REx science data products are identified (i.e. named) according to the SPOC Naming Conventions Document (UA-HBK-9.4.4-905). The following paragraphs are excerpts of this document that describe how OTES files are named. The generalized file naming convention is:

Date/Time + “\_” + Instrument + “\_” + Product Type + “.” + PDS Type

The Date/Time field has variations for different product types.

Products that are collections of frames (instrument integrations) use a UTC date/time string of YYYMMDD”T”HHMMSS”S”FFF”, e.g.( 20170922T231910S306, S306 portion of the time is the sub-second portion of the time). Housekeeping products that are collections of observations (multiple frame sets) are “daily” collections of all observations meaning from midnight to midnight of the day of interest. Products that are made of multiple observations that must be grouped, and span multiple days, use the date of the first observation in the sequence. <https://www.evernote.com/shard/s344/nl/54778328/42d28862-6093-43a8-8555-1064585310bc/> In the case of test data, the UTC time field is the date and time when data is captured on the spacecraft (S/C) test setup; it is converted from S/C SCLK.

The instrument is one of the following:

**Table 4-7: Instrument Abbreviations**

<b>Instrument</b>	<b>Acronym</b>
<b>OCAMS</b>	<b>ocm</b>
<b>PolyCam</b>	<b>pol</b>
<b>MapCam</b>	<b>map</b>
<b>SamCam</b>	<b>sam</b>
<b>NavCam</b>	<b>ncm</b>
<b>NFT</b>	<b>nft</b>
<b>StowCam</b>	<b>stw</b>
<b>OLA</b>	<b>ola</b>
<b>OTES</b>	<b>ote</b>
<b>OVIRS</b>	<b>ovr</b>
<b>REXIS</b>	<b>rex</b>
<b>REXIS Solar-X-Ray Monitor</b>	<b>sxm</b>



The Product Type is the name of the particular data product. The Product Types for OTES are:

**Table 4-8: OTES Data Product Type**

Product Type	Definition
engl0	OTES Level 0 engineering only data
geo	OTES geometric information
scil0	OTES Level 0 science data (interferogram)
engl1	OTES Level 1 engineering only data
scil1	OTES Level 1 science data (voltage spectrum)
scil2	OTES Level 2 calibrated radiance spectrum

The PDS type file suffix indicates the type of file the data product is. OTES data products have one file type suffix, “.dat” (for binary tables). All OTES files are created with detached PDS labels. The labels are PDS compliant XML format labels. Examples of labels can be found in Section 7.4.

## **4.4 Standards Used in Generating Data Products**

### **4.4.1 PDS Standards**

All data products described in this SIS conform to PDS4 standards as described in the PDS Standards document noted in the Applicable Documents section of this SIS. Prior to public release, all data products will have passed both a data product format PDS peer review and a data product production pipeline PDS peer review to ensure compliance with applicable standards.

### **4.4.2 Time Standards**

Time Standards used by the OSIRIS-REx mission conform to PDS time standards. The spacecraft clock (SCLK) reference is 1/1/2000 12:00:00 UTC, with a minimum range date from 1/1/2010 to 1/1/2030. Onboard time tagging is the standard 32-bit seconds and 16-bit subseconds. All OSIRIS-REx data products contain both the spacecraft clock time (SCLK) of data acquisition and a conversion to UTC to facilitate comparison of data products.

### **4.4.3 Coordinate Systems**

All coordinate systems used by the OSIRIS-REx mission conform to IAU standards. A complete discussion of the coordinate systems and how they are deployed in the mission can be found in the document “OSIRIS-REx Coordinate System for Bennu V2” found in the archive documents directory.



#### 4.4.4 Data Storage Conventions

OTES L0-L1 binary data products are stored in the MSB byte order. L2 binary tables are stored in LSB byte order due to data processing equipment constraints. Text products will conform to UTF-8 encoding.

#### 4.5 Data Validation

The SPOC has a comprehensive Verification and Validation (V&V) Plan for all software used at or developed by the SPOC. All software is configuration controlled and any changes made follow the SPOC Configuration Control Plan, which includes substantive testing of changes. During day-to-day production of L0 data products from telemetry, check sums and spot checks are used to validate that software is producing data products correctly.

In addition to software verification and validation, each OSIRIS-REx data product has been peer reviewed for both PDS data format acceptability and scientific usefulness. No changes are expected to data formats after peer review. The SPOC Configuration Control Plan governs any changes, should they be needed.

When data is prepared for submission to the PDS, both the OTES and SPOC Teams will use PDS / mission-provided automated validation tools for conformance to the PDS4 standards. Validation of the science data contained within the OTES data products will, however, occur as a manual inspection by the OTES instrument team and the OSIRIS-REx science team.

## 5 Detailed Data Product Specifications

OTES data products will be organized as tables of records of a homogenous format. A PDS4 label associated with the file will describe the table structure as well as the number of records.

### 5.1 Data Product Structure and Organization

The OSIRIS-REx archive is organized into bundles for each instrument/detector (OCAMS, OTES, OVIRS, OLA, REXIS), TAGSAM, SPICE, DSN, bundles for each discipline specific set of higher-order data products, and a mission bundle with mission-wide context and schema information. Each bundle contains data collections for each data processing level of each data type. Collections will be sub-divided by time interval (mission phase). Each PDS bundle also contains a document collection, to provide the appropriate ancillary information to properly interpret and use the data. All OTES data products are structured as Binary Table files or as Flexible Image Transfer System (FITS) files. OTES data products are organized by type and data processing level and then by mission phase.

The OTES bundle directory structure is as follows:

```
orex.otes
  data_engl0 – raw level 0 instrument engineering data
    cruise_1
    ega
    cruise_2
```

approach  
 preliminary survey  
 orbital a,  
 detailed survey  
 orbital b  
 reconnaissance  
 rehearsal  
 TAG (Touch-and-go)

**data\_engl1 – converted level 1 instrument engineering data**

cruise\_1  
 ega  
 cruise\_2  
 approach  
 preliminary survey  
 orbital a,  
 detailed survey  
 orbital b  
 reconnaissance  
 rehearsal  
 TAG (Touch-and-go)

**data\_raw – level 0 raw spectra data products**

cruise\_1  
 ega  
 cruise\_2  
 approach  
 preliminary survey  
 orbital a,  
 detailed survey  
 orbital b  
 reconnaissance  
 rehearsal  
 TAG (Touch-and-go)

**data\_converted – level 1 voltage spectra data products**

cruise\_1  
 ega  
 cruise\_2  
 approach  
 preliminary survey  
 orbital a,  
 detailed survey  
 orbital b  
 reconnaissance  
 rehearsal  
 TAG (Touch-and-go)

**data\_calibrated – level 2 calibrated spectra data products**

cruise\_1  
 ega  
 cruise\_2  
 approach  
 preliminary survey  
 orbital a,  
 detailed survey  
 orbital b  
 reconnaissance  
 rehearsal  
 TAG (Touch-and-go)

geometry – OTES spatial information data products

- cruise\_1
- ega
- cruise\_2
- approach
- preliminary survey
- orbital a,
- detailed survey
- orbital b
- reconnaissance
- rehearsal
- TAG (Touch-and-go)

document – OTES documentation

## 5.2 Data Format Descriptions

The following sections describe in detail the formats of OTES L0 through L2 data products.

### 5.2.1 L0 Raw(eng) File Format

The Raw engineering data will be stored in a binary table of homogenous records. The file will have an associated PDS4 label describing the table structure and various ancillary fields. The OTES L0 Raw(eng) record structure are given below:

Table 5-1. OTES Elements in the Product\_Observational:Observation\_Area:Mission\_Area of the .XML Label

Element Name	Type	Description
otes:sequence	XML Sequence	Identifies OTES sequence responsible for producing this data product
sequence/id	integer	Numeric identifier of the sequence
sequence/description	text	Text describing the sequence

Table 5-2. OTES Elements in the Product\_Observational:File\_Area\_Observational:Table\_Binary:Record\_Binary of the .XML label. Binary records are stored in MSB byte order.

Field Num	Name	Field Loc (Bytes)	Field Len (Bytes)	Data Type	Units	Description
1	sclk	1	4	UnsignedMSB4	Sec	OTES time in seconds
2	sclk_sub	5	2	UnsignedMSB2		OTES time in sub-seconds. Each count represents 1/(2 <sup>16</sup> ) seconds
3	idp_transaction_counter	7	2	UnsignedMSB2		Counts the number of telemetry transactions (engineering or science) transmitted

RELEASED

Field Num	Name	Field Loc (Bytes)	Field Len (Bytes)	Data Type	Units	Description
4	cip_cmd_echo	9	1	UnsignedByte		Common Instrument Protocol Type of last valid command received
5	idp_cmd_echo	10	1	UnsignedByte		Instrument Dependent Protocol Type of last valid command received
6	cmd_seq_echo	11	1	UnsignedByte		Echo of the Instrument Dependent Protocol Sequence ID of the last valid command received
7	cmd_accept_cnt	12	1	UnsignedByte		Number of accepted commands
8	cmd_rejected_cnt	13	1	UnsignedByte		Number of rejected commands
9	cal_flag_driver_pulse_width	15	1	UnsignedByte		Calibration flag driver pulse width 00 = 50ms; 01 = 100ms; 10 = 150ms.
10	reserved1	14	1	UnsignedByte		Reserved bytes
11	snap_status	20	1	UnsignedByte		SNAP Status, 0 = In Reset, 1 = Running
12	servo_ctrl_status	19	1	UnsignedByte		Servo Controller Status, 0 = Off, 1 = On
13	ir_heater_ctrl_status	18	1	UnsignedByte		IR Heater Controller status, 0 = Off, 1 = On
14	read_table_status	17	1	UnsignedByte		Read Table Status, 0 = Table A, 1 = Table B
15	reserved2	16	1	UnsignedByte		Reserved bytes
16	laser1_power_status	28	1	UnsignedByte		Laser 1 Power Status, 0 = Off, 1 = On
17	laser2_power_status	27	1	UnsignedByte		Laser 2 Power Status, 0 = Off, 1 = On
18	led1_power_status	26	1	UnsignedByte		LED 1 Power Status, 0 = Off, 1 = On
19	led2_power_status	25	1	UnsignedByte		LED 2 Power Status, 0 = Off, 1 = On
20	ir_htr_temp_sel_status	24	1	UnsignedByte		IR Heater Temp Select Status, 0 = Temp 1, 1 = Temp 2
21	cal_flag_status	23	1	UnsignedByte		Cal Flag Status, 0 = Commanded Close, 1 = Commanded Open
22	gravity_comp_status	22	1	UnsignedByte		Gravity Compensation Status, 0 = off, 1 = on
23	sample_direction	21	1	UnsignedByte		Sample Direction 0 = Samples taken during forward motion, 1 =

Field Num	Name	Field Loc (Bytes)	Field Len (Bytes)	Data Type	Units	Description
						Samples taken during backward motion.
24	time_update_cnt	29	1	UnsignedByte		Counts the number of Time Update commands received
25	time_tick_watchdog_cnt	30	1	UnsignedByte		Counts the number of times the time tick counter watchdog has expired
26	sngl_bit_err_cnt	31	1	UnsignedByte		Single Bit Error Counter
27	dbl_bit_err_cnt	32	1	UnsignedByte		Double Bit Error Counter
28	EEPROM_power	33	1	UnsignedByte		EEPROM Power, 0 = Off, 1 = On
29	acq_cal_ick_cnt_err	34	1	UnsignedByte		Acquisition/Calibration ICK Count Error, 0 = No error, 1 = ICK count in Acquisition or Calibration command
30	cal_flag_fault	35	1	UnsignedByte		Cal Flag Fault Protection, 0 = Disabled, 1 = Enabled, Default is disabled
31	cal_flag_fault_timeout	36	1	UnsignedByte		Cal Flag Fault Protection Timeout, 0 = No Timeout, 1 = Fault protection was enabled
32	snap_watchdog	37	1	UnsignedByte		SNAP Watchdog, 0 = Disabled, 1 = Enabled, Default is enabled
33	snap_watchdog_timeout	38	1	UnsignedByte		SNAP Watchdog Timeout, 0 = No timeout, 1 = Timeout
34	diagnostic_enabled	39	1	UnsignedByte		Diagnostic Enable/Disable, 0 = Disabled, 1 = Enabled
35	time_update_fault_protect	40	1	UnsignedByte		Time Update Fault Protection, 0 = Disabled, 1 = Enabled
36	acquisition_id	41	1	UnsignedByte		Acquisition ID Echo from acquisition command
37	ir_gain	42	1	UnsignedByte		8 Bit IR signal gain used during current 2 second scan
38	ick_counter	43	2	UnsignedMSB2		Counts the number of 2 second scans (ICKs) during the execution of an acquisition command
39	sample_counter	45	2	UnsignedMSB2		Indicates the number of samples taken during the current 2 second scan (ICK)
40	zone_status	47	1	UnsignedByte		Displays the current zone (1 – 5) while the Acquisition command is executing

RELEASED

Field Num	Name	Field Loc (Bytes)	Field Len (Bytes)	Data Type	Units	Description
41	table_load_block_status	48	1	UnsignedByte		Indicates the Block Address associated with the Table Load Command
42	table_load_block_checksum	49	4	UnsignedMSB4		Indicates the Block Address associated with the Table Load Command
43	reserved3	53	1	UnsignedByte		Reserved field 3
44	table_store_checksum	54	4	UnsignedMSB4		Indicates the byte by byte summation of table data written to EEPROM via the Table Store Execute command
45	table_read_checksum	58	4	UnsignedMSB4		Indicates the byte by byte summation of table data read from EEPROM on power up
46	reserved4	62	2	UnsignedMSB2		Reserved field 4
47	reserved5	64	2	UnsignedMSB2		Reserved field 5
48	reserved6	66	2	UnsignedMSB2		Reserved field 6
49	reserved7	68	4	UnsignedMSB4		Reserved field 7
50	os_pos_05hz	72	2	UnsignedMSB2		Optical Switch Position. This is the same as 16-bit SNAP parameter Os Pos; but with the MSB dropped to fit into this byte
51	fringe_count	74	2	UnsignedMSB2		Fringe Count. Indicates the number of fringes that occur over the 1.8 second scan window
52	param_subaddress	76	1	UnsignedByte		Identifies the parameter block
53	peak_fringe_signal	77	8	IEEE754MSBD ouble		Peak Fringe Analog Signal. SNAP reports the peak fringe signal over the last 2 second scan period.
54	snap_param_1	85	8	IEEE754MSBD ouble		SNAP Parameter 1 is a set of hardware diagnostic parameters which may have values within the dynamic range of the given data type. The data contained in this parameter is not all the same type and cycles between sets of values that vary significantly from one housekeeping record to the next. Any parameter necessary to use or interpret scientific data are decoded into separate engineering data parameters, e.g fringe_analog

RELEASED

Field Num	Name	Field Loc (Bytes)	Field Len (Bytes)	Data Type	Units	Description
55	snap_param_2	93	8	IEEE754MSBDOUBLE		SNAP Parameter 2 is a set of hardware diagnostic parameters which may have values within the dynamic range of the given data type. The data contained in this parameter is not all the same type and cycles between sets of values that vary significantly from one housekeeping record to the next. Any parameter necessary to use or interpret scientific data are decoded into separate engineering data parameters, e.g fringe_analog
56	snap_param_3	101	8	IEEE754MSBDOUBLE		SNAP Parameter 3 is a set of hardware diagnostic parameters which may have values within the dynamic range of the given data type. The data contained in this parameter is not all the same type and cycles between sets of values that vary significantly from one housekeeping record to the next. Any parameter necessary to use or interpret scientific data are decoded into separate engineering data parameters, e.g fringe_analog
57	snap_param_4	109	8	IEEE754MSBDOUBLE		SNAP Parameter 4 is a set of hardware diagnostic parameters which may have values within the dynamic range of the given data type. The data contained in this parameter is not all the same type and cycles between sets of values that vary significantly from one housekeeping record to the next. Any parameter necessary to use or interpret scientific data are decoded into separate engineering data parameters, e.g fringe_analog
58	fringe_analog	117	2	UnsignedMSB2		Fringe Analog. Average of 8 samples taken relative to the time stamp
59	tach_analog	119	2	UnsignedMSB2		Motor Tachometer Analog. Average of 8 samples taken relative to the time stamp
60	reserved9	121	2	UnsignedMSB2		Reserved field 9

RELEASED

Field Num	Name	Field Loc (Bytes)	Field Len (Bytes)	Data Type	Units	Description
61	reserved10	123	2	UnsignedMSB2		Reserved field 10
62	ir_detector_temp_1_analog	125	2	UnsignedMSB2	DN	Temperature of IR detector – sensor 1
63	ir_detector_temp_2_analog	127	2	UnsignedMSB2	DN	Temperature of IR detector – sensor 2
64	black_body_temp_1_analog	129	2	UnsignedMSB2	DN	Temperature of black body – sensor 1
65	black_body_temp_2_analog	131	2	UnsignedMSB2	DN	Temperature of black body – sensor 2
66	primary_mirror_temp_1_analog	133	2	UnsignedMSB2	DN	Temperature of primary mirror – sensor 1
67	primary_mirror_temp_2_analog	135	2	UnsignedMSB2	DN	Temperature of primary mirror – sensor 2
68	secondary_mirror_tmp_1_analog	137	2	UnsignedMSB2	DN	Temperature of secondary mirror – sensor 1
69	secondary_mirror_tmp_2_analog	139	2	UnsignedMSB2	DN	Temperature of secondary mirror – sensor 2
70	cal_ref_temp_analog	141	2	UnsignedMSB2	DN	Temperature of calibration reference
71	cal_actuator_temp_analog	143	2	UnsignedMSB2	DN	Temperature of calibration flag actuator
72	beam_splitter_temp_analog	145	2	UnsignedMSB2	DN	Temperature of beamsplitter
73	laser_temp_analog	147	2	UnsignedMSB2	DN	Temperature of laser
74	motor_temp_analog	149	2	UnsignedMSB2	DN	Temperature of motor
75	cal_res_1_analog	151	2	UnsignedMSB2	DN	Value of calibration resistor 1
76	cntrl_brd_temp_analog	153	2	UnsignedMSB2	DN	Temperature of control board
77	cal_res_2_analog	155	2	UnsignedMSB2	DN	Value of calibration resistor 2
78	agnd_status_analog	157	2	UnsignedMSB2	DN	Analog Ground Status. Average of 8 samples taken relative to the time stamp
79	pos15v_status_analog	159	2	UnsignedMSB2	DN	+15V Status. Average of 8 samples taken relative to the time stamp
80	pos12v_status_analog	161	2	UnsignedMSB2	DN	+12V Status. Average of 8 samples taken relative to the time stamp
81	pos10v_status_analog	163	2	UnsignedMSB2	DN	+10V Status. Average of 8 samples taken relative to the time stamp



Field Num	Name	Field Loc (Bytes)	Field Len (Bytes)	Data Type	Units	Description
82	pos5v_status_analog	165	2	UnsignedMSB2	DN	+5V Status. Average of 8 samples taken relative to the time stamp
83	pos3_3v_status_analog	167	2	UnsignedMSB2	DN	+3.3V Status. Average of 8 samples taken relative to the time stamp
84	pos2_5v_status_analog	169	2	UnsignedMSB2	DN	+2.5V Status. Average of 8 samples taken relative to the time stamp
85	pos1_5v_status_analog	171	2	UnsignedMSB2	DN	+1.5V Status. Average of 8 samples taken relative to the time stamp
86	neg15v_status_analog	173	2	UnsignedMSB2	DN	-15V Status. Average of 8 samples taken relative to the time stamp
87	neg12v_status_analog	175	2	UnsignedMSB2	DN	-12V Status. Average of 8 samples taken relative to the time stamp
88	neg5v_status_analog	177	2	UnsignedMSB2	DN	-5V Status. Average of 8 samples taken relative to the time stamp

### 5.2.2 L0 Raw(science) File Format

The raw(science) look data will be stored in a binary table of homogenous records. The file will have an associated PDS4 label describing the table structure and various ancillary fields in addition to what the Raw(eng) file format has. The additional header fields are as follows:

**Table 5-3. Additional OTES Elements in the Product\_Observational:Observation\_Area:Mission\_Area of the .XML Label for Raw(science) products**

Element Name	Type	Description
command	XML Sequence	Identifies OTES command responsible for producing this data product
command/id	integer	Numeric identifier of the command
command/ parameters	text	Text containing the command parameters

Look record structure is the same as the engineering record structure with the addition of the interferogram field added to the end of the engineering record. The additional interferogram field's structure is given below:

**Table 5-4. Additional OTES Elements in the Product\_Observational:File\_Area\_Observational:Table\_Binary:Record\_Binary of the .XML label for Raw(science) products. The table is identical to the L0 Raw(eng) with the additional 89<sup>th</sup> field containing the interferogram.**

Field Num	Name	Field Loc (Bytes)	Field Length (Bytes)	Data Type	Units	Description
89	science_data	179	2828	UnsignedMSB2	DN	OTES science interferogram. Data stored in big endian.

### 5.2.3 L1 Converted(eng) File Format

The converted engineering data are stored in a binary table of homogenous records. The file will have an associated PDS4 label describing the table structure and various ancillary fields. This table is identical in structure to raw engineering products, except that values have been converted from DN to engineering units in fields with “\_x” appended to the column name.

Field Number	Name	Field Location (Bytes)	Field Length (Bytes)	Data Type	Units	Description
1	selk	1	4	UnsignedMSB4	Sec	OTES time in seconds
2	selk_sub	5	2	UnsignedMSB2		OTES time in sub-seconds. Each count represents 1/(2 <sup>16</sup> ) seconds
3	idp_transaction_counter	7	2	UnsignedMSB2		Counts the number of telemetry transactions (engineering or science) transmitted
4	cip_cmd_echo	9	1	UnsignedByte		Common Instrument Protocol Type of last valid command received
5	idp_cmd_echo	10	1	UnsignedByte		Instrument Dependent Protocol Type of last valid command received
6	cmd_seq_echo	11	1	UnsignedByte		Echo of the Instrument Dependent Protocol Sequence ID of the last valid command received
7	cmd_accept_cnt	12	1	UnsignedByte		Number of accepted commands

RELEASED

Field Number	Name	Field Location (Bytes)	Field Length (Bytes)	Data Type	Units	Description
8	cmd_rejected_cnt	13	1	UnsignedByte		Number of rejected commands
9	cal_flag_driver_pulse_width	14	1	UnsignedByte		Calibration flag driver pulse width 00 equals 50ms; 01 equals 100ms; 10 equals 150ms.
10	reserved1	15	1	UnsignedByte		Reserved bytes
11	snap_status	16	1	UnsignedByte		SNAP Status, 0 = In Reset, 1 = Running
12	servo_ctrl_status	17	1	UnsignedByte		Servo Controller Status, 0 = Off, 1 = On
13	ir_heater_ctrl_status	18	1	UnsignedByte		IR Heater Controller status, 0 = Off, 1 = On
14	read_table_status	19	1	UnsignedByte		Read Table Status, 0 = Table A, 1 = Table B
15	reserved2	20	1	UnsignedByte		Reserved bytes
16	laser1_power_status	21	1	UnsignedByte		Laser 1 Power Status, 0 = Off, 1 = On
17	laser2_power_status	22	1	UnsignedByte		Laser 2 Power Status, 0 = Off, 1 = On
18	led1_power_status	23	1	UnsignedByte		LED 1 Power Status, 0 = Off, 1 = On
19	led2_power_status	24	1	UnsignedByte		LED 2 Power Status, 0 = Off, 1 = On
20	ir_htr_temp_sel_status	25	1	UnsignedByte		IR Heater Temp Select Status, 0 = Temp 1, 1 = Temp 2
21	cal_flag_status	26	1	UnsignedByte		Cal Flag Status, 0 = Commanded Close, 1 = Commanded Open
22	gravity_comp_status	27	1	UnsignedByte		Gravity Compensation Status, 0 = off, 1 = on
23	sample_direction	28	1	UnsignedByte		Sample Direction, 0 = samples taken during forward motion, 1 = samples taken during backward motion
24	time_update_cnt	29	1	UnsignedByte		Counts the number of Time Update commands received
25	time_tick_watchdog_cnt	30	1	UnsignedByte		Counts the number of times the time tick counter watchdog has expired
26	sngl_bit_err_cnt	31	1	UnsignedByte		Single Bit Error Counter
27	dbl_bit_err_cnt	32	1	UnsignedByte		Double Bit Error Counter

RELEASED

Field Number	Name	Field Location (Bytes)	Field Length (Bytes)	Data Type	Units	Description
28	eeeprom_power	33	1	UnsignedByte		EEPROM Power, 0 = Off, 1 = On
29	acq_cal_ick_cnt_err	34	1	UnsignedByte		Acquisition/Calibration ICK Count Error, 0 = No error, 1 = ICK count in Acquisition or Calibration command
30	cal_flag_fault	35	1	UnsignedByte		Cal Flag Fault Protection, 0 = Disabled, 1 = Enabled, Default is disabled
31	cal_flag_fault_timeout	36	1	UnsignedByte		Cal Flag Fault Protection Timeout, 0 = No Timeout, 1 = Fault protection was enabled
32	snap_watchdog	37	1	UnsignedByte		SNAP watchdog , 0 = Disabled, 1 = Enabled, Default is enabled
33	snap_watchdog_timeout	38	1	UnsignedByte		SNAP Watchdog Timeout, 0 = No timeout, 1 = Timeout
34	diagnostic_enabled	39	1	UnsignedByte		Diagnostic Enable/Disable, 0 = Disabled, 1 = Enabled
35	time_update_fault_protect	40	1	UnsignedByte		Time Update Fault Protection, 0 = Disabled, 1 = Enabled
36	acquisition_id	41	1	UnsignedByte		Acquisition ID Echo from acquisition command
37	ir_gain	42	1	UnsignedByte		8 Bit IR signal gain used during current 2 second scan
38	ick_counter	43	2	UnsignedMSB2		Counts the number of 2 second scans (ICKs) during the execution of an acquisition command
39	sample_counter	45	2	UnsignedMSB2		Indicates the number of samples taken during the current 2 second scan (ICK)
40	zone_status	47	1	UnsignedByte		Displays the current zone (1 – 5) while the Acquisition command is executing
41	table_load_block_status	48	1	UnsignedByte		Indicates the Block Address associated with the Table Load Command
42	table_load_block_checksum	49	4	UnsignedMSB4		Indicates the Block Address associated with the Table Load Command
43	reserved3	53	1	UnsignedByte		Reserved field 3

RELEASED

Field Number	Name	Field Location (Bytes)	Field Length (Bytes)	Data Type	Units	Description
44	table_store_checksum	54	4	UnsignedMSB4		Indicates the byte by byte summation of table data written to EEPROM via the Table Store Execute command
45	table_read_checksum	58	4	UnsignedMSB4		Indicates the byte by byte summation of table data read from EEPROM on power up
46	reserved4	62	2	UnsignedMSB2		Reserved field 4
47	reserved5	64	2	UnsignedMSB2		Reserved field 5
48	reserved6	66	2	UnsignedMSB2		Reserved field 6
49	reserved7	68	4	UnsignedMSB4		Reserved field 7
50	os_pos_05hz	72	4	IEEE754MSBSingle		Optical Switch Position. This is the same as 16-bit SNAP parameter Os Pos; but with the MSB dropped to fit into this byte
51	fringe_count	76	2	UnsignedMSB2		Fringe Count. Indicates the number of fringes that occur over the 1.8 second scan window
52	param_subaddress	78	1	UnsignedByte		Identifies the parameter block
53	peak_fringe_signal	79	8	IEEE754MSBDouble		Peak Fringe Analog Signal. SNAP reports the peak fringe signal over the last 2 second scan period.
54	snap_param_1	87	8	IEEE754MSBDouble		SNAP Parameter 1 is a set of hardware diagnostic parameters which may have values within the dynamic range of the given data type. The data contained in this parameter is not all the same type and cycles between sets of values that vary significantly from one housekeeping record to the next. Any parameter necessary to use or interpret scientific data are decoded into separate engineering data parameters, e.g fringe_analog
55	snap_param_2	95	8	IEEE754MSBDouble		SNAP Parameter 2 is a set of hardware diagnostic parameters which may have values within the dynamic range of the given data type. The data contained in this

RELEASED

Field Number	Name	Field Location (Bytes)	Field Length (Bytes)	Data Type	Units	Description
						parameter is not all the same type and cycles between sets of values that vary significantly from one housekeeping record to the next. Any parameter necessary to use or interpret scientific data are decoded into separate engineering data parameters, e.g fringe_analog
56	snap_param_3	103	8	IEEE754MSBDouble		SNAP Parameter 2 is a set of hardware diagnostic parameters which may have values within the dynamic range of the given data type. The data contained in this parameter is not all the same type and cycles between sets of values that vary significantly from one housekeeping record to the next. Any parameter necessary to use or interpret scientific data are decoded into separate engineering data parameters, e.g fringe_analog
57	snap_param_4	111	8	IEEE754MSBDouble		SNAP Parameter 2 is a set of hardware diagnostic parameters which may have values within the dynamic range of the given data type. The data contained in this parameter is not all the same type and cycles between sets of values that vary significantly from one housekeeping record to the next. Any parameter necessary to use or interpret scientific data are decoded into separate engineering data parameters, e.g fringe_analog
58	fringe_analog_x	119	4	IEEE754MSBSingle		Fringe Analog. Average of 8 samples taken relative to the time stamp
59	tach_analog_x	123	4	IEEE754MSBSingle		Motor Tachometer Analog. Average of 8 samples taken relative to the time stamp
60	reserved9	127	2	UnsignedMSB2		Reserved field 9
61	reserved10	129	2	UnsignedMSB2		Reserved field 10

RELEASED

Field Number	Name	Field Location (Bytes)	Field Length (Bytes)	Data Type	Units	Description
62	ir_detector_temp_1_analog_x	131	4	IEEE754MSBSingle	Deg C	Temperature of IR detector – sensor 1
63	ir_detector_temp_2_analog_x	135	4	IEEE754MSBSingle	Deg C	Temperature of IR detector – sensor 2
64	black_body_temp_1_analog_x	139	4	IEEE754MSBSingle	Deg C	Temperature of black body – sensor 1
65	black_body_temp_2_analog_x	143	4	IEEE754MSBSingle	Deg C	Temperature of black body – sensor 2
66	primary_mirror_temp_1_analog_x	147	4	IEEE754MSBSingle	Deg C	Temperature of primary mirror – sensor 1
67	primary_mirror_temp_2_analog_x	151	4	IEEE754MSBSingle	Deg C	Temperature of primary mirror – sensor 2
68	secondary_mirror_tmp_1_anlog_x	155	4	IEEE754MSBSingle	Deg C	Temperature of secondary mirror – sensor 1
69	secondary_mirror_tmp_2_anlog_x	159	4	IEEE754MSBSingle	Deg C	Temperature of secondary mirror – sensor 2
70	cal_ref_temp_analog_x	163	4	IEEE754MSBSingle	Deg C	Temperature of calibration reference
71	cal_actuator_temp_analog_x	167	4	IEEE754MSBSingle	Deg C	Temperature of calibration flag actuator
72	beam_splitter_temp_analog_x	171	4	IEEE754MSBSingle	Deg C	Temperature of beamsplitter
73	laser_temp_analog_x	175	4	IEEE754MSBSingle	Deg C	Temperature of laser
74	motor_temp_analog_x	179	4	IEEE754MSBSingle	Deg C	Temperature of motor
75	cal_res_1_analog_x	183	4	IEEE754MSBSingle	Ohm	Value of calibration resistor 1
76	cntrl_brd_temp_analog_x	187	4	IEEE754MSBSingle	Deg C	Temperature of control board
77	cal_res_2_analog_x	191	4	IEEE754MSBSingle	Ohm	Value of calibration resistor 2
78	agnd_status_analog_x	195	4	IEEE754MSBSingle	Volts	Analog Ground Status. Average of 8 samples taken relative to the time stamp
79	pos15v_status_analog_x	199	4	IEEE754MSBSingle	Volts	+15V Status. Average of 8 samples taken relative to the time stamp
80	pos12v_status_analog_x	203	4	IEEE754MSBSingle	Volts	+12V Status. Average of 8 samples taken relative to the time stamp
81	pos10v_status_analog_x	207	4	IEEE754MSBSingle	Volts	+10V Status. Average of 8 samples taken relative to the time stamp

Field Number	Name	Field Location (Bytes)	Field Length (Bytes)	Data Type	Units	Description
82	pos5v_status_analog_x	211	4	IEEE754MSBSingle	Volts	+5V Status. Average of 8 samples taken relative to the time stamp
83	pos3_3v_status_analog_x	215	4	IEEE754MSBSingle	Volts	+3.3V Status. Average of 8 samples taken relative to the time stamp
84	pos2_5v_status_analog_x	219	4	IEEE754MSBSingle	Volts	+2.5V Status. Average of 8 samples taken relative to the time stamp
85	pos1_5v_status_analog_x	223	4	IEEE754MSBSingle	Volts	+1.5V Status. Average of 8 samples taken relative to the time stamp
86	neg15v_status_analog_x	227	8	IEEE754MSBDouble	Volts	-15V Status. Average of 8 samples taken relative to the time stamp
87	neg12v_status_analog_x	235	4	IEEE754MSBSingle	Volts	-12V Status. Average of 8 samples taken relative to the time stamp
88	neg5v_status_analog_x	239	4	IEEE754MSBSingle	Volts	-5V Status. Average of 8 samples taken relative to the time stamp

### 5.2.4 L1 Converted(science) File Format

The converted(science) look data will be stored in a binary table of homogenous records. The file will have an associated PDS4 label describing the table structure and various ancillary fields. The converted(science) product has the same fields as the L1 Converted(eng) product with the addition of the converted interferogram in field number 89.

Field Number	Name	Field Location (Bytes)	Field Length (Bytes)	Data Type	Units	Description
89	science_data	243	11312	IEEE754MSBDouble	Volts	OTES science interferogram, post conversion. Data stored in big endian.

### 5.2.5 Geo File Format

The Geo file is a FITS format binary table that contains the observation geometry for each OTES interferogram/spectrum taken. Geometry is related to either the interferogram or resulting spectrum by the sclk\_string value identical to the seconds\_raw attribute in the (eng)



or (sci) product. FITS files are used as the geometry calculations are done for multiple instruments on the mission, and the output is generic.

**Table 5-5. Geo File format**

Field Number	Name	Field Location (Bytes)	Field Length (Bytes)	Data Type	Units	Description
1	sclk_string	1	51	ASCII_String		The SCLK string of the instrument clock at the beginning of the collection interval
2	utc	52	51	ASCII_String	Sec	The UTC time of the instrument clock
3	latitude	103	4	IEEE754MSBSingle	Deg	Latitude of instrument boresight intersection with the surface Bennu body-fixed coordinates. Allowed range +90.0 to -90.0. If Boresight Flag NE 1, then value shall be -9999
4	longitude	107	4	IEEE754MSBSingle	Deg	Longitude of instrument boresight intersection with the surface in Bennu body-fixed coordinates. Allowed range 0 to 360. If Boresight Flag NE 1, then value shall be -9999
5	ltime	111	51	ASCII_String		Mean local solar time of instrument boresight intersection point with target in the body fixed frame
6	right_ascension	162	4	IEEE754MSBSingle	Deg	Boresight Right Ascension (RA) in J2000 frame
7	declination	166	4	IEEE754MSBSingle	Deg	Boresight Declination (DEC) in J2000 frame
8	boresight_x	170	4	IEEE754MSBSingle	m	X-coordinate of boresight intersection with surface of target in planetocentric Cartesian coordinates. Allowed range 0 to 1000.0. If Boresight Flag NE 1, then value shall be -9999.
9	boresight_y	174	4	IEEE754MSBSingle	m	Y-coordinate of boresight intersection with surface of target in planetocentric Cartesian coordinates. Allowed range 0 to 1000.0. If Boresight Flag NE 1, then value shall be -9999
10	boresight_z	178	4	IEEE754MSBSingle	m	Z-coordinate of boresight intersection with surface of target in planetocentric Cartesian coordinates. Allowed range 0 to

RELEASED

Field Number	Name	Field Location (Bytes)	Field Length (Bytes)	Data Type	Units	Description
						1000.0. If Boresight Flag NE 1, then value shall be -9999.
11	boresight_dir_x	182	4	IEEE754MSBSingle		Body-fixed X of boresight direction unit vector
12	boresight_dir_y	186	4	IEEE754MSBSingle		Body-fixed Y of boresight direction unit vector
13	boresight_dir_z	190	4	IEEE754MSBSingle		Body-fixed Z of boresight direction unit vector
14	bore_flag	194	2	SignedMSB2		Flag indicating if the instrument boresight intersects the surface of Bennu. 0 = no intersection, 1 = intersection
15	incidence_angle	196	4	IEEE754MSBSingle	Deg	Incidence angle. The angle between the vector normal to the surface at the location of the boresight intersection with the surface and the vector pointing at the Sun. If Boresight Flag NE 1, then value shall be -9999. Allowed range is 0.0 to 90.0
16	emission_angle	200	4	IEEE754MSBSingle	Deg	Emission angle. The angle between the vector normal to the surface at the location of the boresight intersection with the surface and the vector pointing to the Spacecraft. If Boresight Flag NE 1, then value shall be -9999. Allowed range is 0.0 to 90.0
17	phase_angle	204	4	IEEE754MSBSingle	Deg	Phase Angle. The angle between the vector pointing to the Sun and the vector pointing to the Spacecraft. If Boresight Flag NE 1, then value shall be -9999. Allowed range is 0.0 to 180.0
18	range	208	4	IEEE754MSBSingle	km	Range from S/C to boresight intersection with target surface
19	target_range	212	4	IEEE754MSBSingle	km	Range from S/C to target body center
20	resolution	216	4	IEEE754MSBSingle	m/deg	Spatial resolution of data on the surface of Bennu. Geometry calculation from spacecraft range.

Field Number	Name	Field Location (Bytes)	Field Length (Bytes)	Data Type	Units	Description
21	fov_diameter_distance	220	4	IEEE754MSBSingle		The number of fields of view the boresight is offset from the target (Bennu).
22	look_type	228	20	ASCII_String		The type of data contained in the look, data-look, space-look, or calibration-look

### 5.2.6 L2 Calibrated Radiance File Format

An OTES calibrated radiance file will be composed of a binary table of homogenous records. The file will have a detached XML label to describe contents and format. Note that the L2 data product is stored in LSB byte order. This is different than the previous products and is due to data processing equipment changes.

**Table 5-6. OTES Elements in the Product\_Observational:Observation\_Area:Mission\_Area of the .XML Label for calibrated radiance products**

Element Name	Type	Description
sequence	XML Sequence	Identifies OTES sequence responsible for producing this data product
sequence/id	integer	Numeric identifier of the sequence
sequence/description	text	Text describing the sequence

The calibrated radiance data records will have the following structure:

**Table 5-7. OTES Elements in the Product\_Observational:File\_Area\_Observational of the .XML label for calibrated radiance products**

Field Name	Type x element count	Description
sclk	UnsignedLSB4	Spacecraft clock at the start of an OTES mirror scan
sclk_sub	UnsignedLSB2	Sub-second part of sclk, each count is 1/65536 <sup>th</sup> of a second
ick	UnsignedLSB2	Instrument counter keeper
flags	UnsignedLSB2	Flags

Field Name	Type x element count	Description
cal_rad	IEEE754LSBSingle x 349	Calibrated radiance spectrum ( $W\ CM^{-2}\ SR^{-1}$ / $CM^{-1}$ )
Brightness_temp_uncertainty	IEEE754LSBSingle	Uncertainty value associated with derived maximum brightness temperature
Max_brightness_temp	IEEE754LSBSingle	Maximum surface temperature
xaxis	IEEE754LSBSingle x 349	Wavenumbers in the radiance spectrum.

### 5.3 Label and Header Descriptions

All OTES data products are produced with PDS4 compliant detached XML labels. Examples of these labels can be found in Appendix 7.4.

## 6 Applicable Software

The OTES team will use “Davinci” (<http://davinci.mars.asu.edu>) to examine, display and analyze the data products. Davinci is a hyperspectral image processing software produced by the Mars Space Flight Facility at Arizona State University, Tempe, AZ 85287. It has been used as the calibration and analysis software for multiple missions, including MGS/TES, Odyssey/THEMIS, and MER/Mini-TES. The minimum release number for Davinci to access and open PDS4 and FITS Files is 2.17.

Davinci will be maintained by the Davinci development team at ASU. Feature requests and bugs may be submitted via email to the Davinci development team.

PDS4 XML labels can be opened using most XML aware text editors.

PDS4 utility programs such as the PDS4 Viewer and other IDL- and Python based PDS4 readers are available through the PDS Tool Registry (<https://pds.jpl.nasa.gov/tools/tool-registry/>)

### 6.1 Utility Programs

Davinci depends upon “gnuplot” for its plotting needs and an external image viewer to display images. Location of both is controlled via environment variables as described on the Davinci web-site. Standard complement of Linux/Unix tools and scripting languages will be used in conjunction as needed. Examples of such utilities include “od”, “dd”, “awk”, “perl”

(<http://www.perl.org>), “xmlstarlet” (<http://xmlstar.sourceforge.net>) for data dump, selection, formatting and xml query etc.

## **6.2 Applicable PDS Software Tools**

The PDS supplies a number of software tools that can be used in conjunction with PDS data products. Please refer to the PDS4 software website (<http://pds.nasa.gov/pds4/software/index.shtml>) for additional information on these tools.

## **6.3 Software Distribution and Update Procedures**

Current and future releases of Davinci will be available from its web-site (<http://davinci.mars.asu.edu>) in both source and binary forms. Its documentation is hosted on the same site.

## 7 Appendices

### 7.1 Glossary

TERM	DESCRIPTION
Data look	Interferogram+engineering data acquired while looking at Bennu
Davinci	Hyperspectral image processing software used by the OTES Team for data processing.
Internal-calibration look	Interferogram+engineering data acquired while looking at the OTES calibration flag
NaN	IEEE Quiet NaN (or Not-a-Number) value
Observation Sequence	OTES sequence, a collection of data tagged with the same sequence-id. Since sequence-ids can roll-over, they are only unique in a limited time window.
Space-calibration look	Interferogram+engineering data acquired while staring into the space without interference from another object
OTES Cal/Val Pipeline	SPOC utility programs that move spectral data from a file into the SPOC Data Repository Database

### 7.2 Acronyms

TERM	DESCRIPTION
APID	Application Process Identifier
ASU	Arizona State University
CIP	Common Instrument Protocol
CSPICE	C-version of SPICE library from NAIF.
CSV	Comma Separated Value text file
DFT	Discrete Fourier Transform
DRM	Design Reference Mission
DTD	Data Type Definition

TERM	DESCRIPTION
FOV	Field Of View
ICK	Instrument Counter Keeper – A counter within OTES which increments every two seconds. It counts acquired looks.
IDP	Instrument Dependent Protocol
IP	Internet Protocol
LSB	Least Significant Byte first
MB	Megabyte
NAIF	The Navigation and Ancillary Information Facility
NTE	Not To Exceed
OSIRIS-REx	Origins, Spectral Interpretation, Resource Identification, Security – Regolith Explorer
OTES	OSIRIS-REx Thermal Emission Spectrometer
PC	Personal Computer
PDS	Planetary Data Systems
PDS4	PDS version 4 standard
RDR	Reduced Data Record
SFDU	Standard Format Data Unit
SPOC	Science Processing and Operations Center
SPOC TDP	SPOC Telemetry Data Processor
TBD	To Be Determined
TBR	To Be Revised
UDP	User Datagram Protocol
UTC	Coordinated Universal Time
XML	Extensible Markup Language

### 7.3 Definitions of Data Processing Levels

Level	Definition	
	OREx Level 0	<i>Raw.</i> Raw instrument data reconstructed from telemetry with header and ancillary information appended. Appended header and ancillary data is data necessary for further processing.
	OREx Level 1	<i>Uncalibrated.</i> Data in one of the fundamental structures. This data will be archived to the PDS.
	OREx Level 2	<i>Reversibly calibrated.</i> Data in units proportional to physical units. Since PDS allows offsets and scaling factors in its array and table structures, this would be the minimum level capable of satisfying the “in physical units” requirement. This data will be archived to the PDS
	OREx Level 3	<i>Irreversibly processed.</i> Higher-level products from a single source that cannot be losslessly converted back to the lower-level products from which they were derived. These might also satisfy the “in physical units” requirement. Data products of this processing level will be archived to the PDS according to DMP-Table 19
	OREx Level 4	<i>Derived data.</i> Products created by combining data from more than one source (instrument, observer, etc.). Data products of this processing level will be archived to the PDS according to DMP-Table 19

### 7.4 Example PDS Labels

Example labels can be found in the OTES bundle document collection in a sub-directory named “example\_labels”. There are example labels for each type of OTES data product.