

Origins Spectral Interpretation Resource Identification Security-Regolith Explorer (OSIRIS-REx) Project

OSIRIS-REx Visible and Infrared Spectrometer (OVIRS) Uncalibrated / Calibrated Data Product Software Interface Specification

UA-SIS-9.4.4-306, Rev. 7.0

RELEASED

Revision – 7.0

April 27, 2020



CM FOREWORD

This document is an OSIRIS-REx Project controlled document. Changes to this document require prior approval of the OSIRIS-REx Configuration Control Board (CCB) and Configuration Management Lead (CML). Proposed changes shall be submitted to the OSIRIS-REx Project CML, along with supportive material justifying the proposed change.

Questions or comments concerning this document should be addressed to:

SPOC Configuration Management Team
1415 N. 6th Avenue
Tucson, AZ 85705

Email: spoc-cm@orex.lpl.arizona.edu

OSIRIS-REx Project

OVIRS Uncalibrated / Calibrated Data

Product SIS

SIGNATURE PAGE

Prepared By:

___ on file

M. Katherine Crombie, Indigo Information Services, LLC
OSIRIS-REx PDS Lead

Date

___ on file

Allen Lunsford
OVIRS Software Lead

Date

Approved By:

On file

Karl Harshman
SPOC Manager

Date

On file
Nathan Mogk
SPOC Systems Engineer

Date

On file

Mike Fitzgibbon
SPOC Cal/Val Lead

Date

On file
Dennis Reuter
OVIRS Instrument Scientist

Date

On file
Amy Simon
OVIRS Deputy Instrument Scientist

Date

DOCUMENT CHANGE LOG

REV / VERSION LEVEL	DESCRIPTION OF CHANGE	APPROVED BY	DATE APPROVED
0.1	Initial Draft of Document	MKC	12/06/2013
0.2	Changes to all sections based on initial OVIRS document delivery to SPOC 4/5/2013		7/31/2013
0.3	Changes to all sections based on baseline OVIRS document delivery 10/01/2013		11/30/2013
0.4	Update by OVIRS team. Delivery 3/31/2014		
0.5	Data Formats update by SPOC- 04/11/2014		
0.8	Update of all sections from OVIRS team		12/16/2014
1.0	Final update of all sections before CM		01/21/2015
2.0	Update of signature page to reflect current roles and responsibilities Update sections consistent with ECR-0024 Update by OVIRS team to reflect SPOC pipeline Build 3 modifications	ECR-0025	06/20/2016
3.0	Update per Change Requests	CR-67, CR-234, CR-252	06/04/2018
4.0	Update per Change Request	CR-331	11/02/2018
4.0	Karl Harshman's signature was not needed for 4.0; signature block re-added and noted as unnecessary for revision instead of signature block being fully removed.	N/A	01/10/2019
5.0	Update per CR	CR-390	01/23/2019
5.n	Update per CR	CR-401	03/01/2019
6.0	Signatures	N/A	4/19/2019
6.n	Update per CR	CR-459	02/03/2020
7.0	Signatures	N/A	4/27/2020

LIST OF TBDs/TDRs

SECTION ID	DESCRIPTION OF TBD/TBR	DATE OF RESOLUTION
7.5	Example PDS Labels	3/15/2015
Table 5	Data Volume to be updated on latest version of DRM	3/15/2015

TABLE OF CONTENTS

1 Purpose and Scope 8

2 Applicable Documents and Constraints..... 8

3 Relationships with Other Interfaces..... 8

4 Data Product Characteristics and Environment 9

4.1 Instrument Overview 9

4.1.1 Calibration Sources..... 12

4.1.2 Detector segmentation (Regions of Interest) 12

4.1.3 Data Processing Modes..... 13

4.1.4 Data Formats..... 14

4.2 Data Product Overview..... 14

4.3 Data Processing..... 15

4.3.1 Data Processing Level..... 16

4.3.2 Data Product Generation..... 16

4.3.2.1 Level 0 – Raw Science and Housekeeping Data 16

4.3.2.2 Level 1 – Processed Housekeeping Data 18

4.3.2.3 Level 2 – Calibrated Science Data..... 18

4.3.3 Data Flow..... 20

4.3.4 Labeling and Identification 21

4.4 Standards Used in Generating Data Products 25

4.4.1 PDS Standards 25

4.4.2 Time Standards 25

4.4.3 Coordinate Systems 25

4.4.4 Data Storage Conventions..... 25

4.5 Data Validation 25

5 Detailed Data Product Specifications 26

5.1 Data Product Structure and Organization 26

5.2 Data Format Descriptions 27

5.2.1 OVIRS L0 Science Data 27

5.2.2 OVIRS L2 CALIBRATED SCIENCE DATA..... 35

5.2.3 OVIRS L0 HOUSEKEEPING..... 40

5.2.4 OVIRS L1 HOUSEKEEPING..... 45

5.3	Label and Header Descriptions.....	51
6	Applicable Software.....	51
6.1	Utility Programs.....	51
6.2	Applicable PDS Software Tools.....	51
6.3	Software Distribution and Update Procedures.....	51
7	Appendix.....	52
7.1	Acronyms.....	52
7.2	References.....	52
7.3	Definitions of Data Processing Levels.....	53
7.4	Example PDS Labels	54

LIST OF FIGURES

Figure 1.	The OVIRS Instrument.....	10
Figure 2.	OVIRS Regions of Interest, and Modes	13
Figure 3.	OVIRS Ingest/Digest Data Flow	17
Figure 4.	OVIRS Cal/Val Pipeline Invocation	20
Figure 5.	Wavelength Array Diagram	35

LIST OF TABLES

Table 3-1.	Interface Relationships	9
Table 4-1.	OVIRS Observation Profile.....	11
Table 4-2.	OVIRS Data Processing Levels.....	16
Table 4-3.	OVIRS science telemetry data header “House Keeping Data” field definition	17
Table 4-4.	OVIRS Quality Flag Description	19
Table 4-5.	OVIRS Data Products/ Volume by Mission Phase	21
Table 4-6.	Instrument Abbreviations	23
Table 4-7.	OVIRS Product Type	23
Table 4-8.	OVIRS Calibration Type.....	24
Table 4-9.	OVIRS Calibration File Detector Values.....	24
Table 5-1.	OVIRS L0 Science Data Product –Primary Data Unit/Array_3d_Image	28
Table 5-2.	OVIRS L0 Science Data Products – Secondary Data Unit/Table_Binary. Note that the first record of this table corresponds to the first frame of data in the primary data unit.Array_3d_Image (Table 5-1).....	29
Table 5-3.	OVIRS Calibrated Science Data Format.....	36
Table 5-4.	OVIRS L0 Housekeeping.....	40
Table 5-5.	OVIRS L1 Housekeeping Data Product.....	45
Table 7-1.	Data Processing Levels.....	53

1 Purpose and Scope

The data products described by this Software Interface Specification (SIS) are the OSIRIS-REx Visible and near-IR Spectrometer (OVIRS) raw, uncalibrated and calibrated data products. The OSIRIS-REx Science Processing and Operation Center located at the University of Arizona produces these data products and distributes them to both the OSIRIS-REx Science Team and the Planetary Data System.

The purpose of this document is to provide users of the data product with a detailed description of the product and a description of how it was generated, including data sources and destinations. The document is intended to provide enough information to enable users to read and understand the data product. The users for whom this document is intended are the scientists who will analyze the data, including those associated with the project and those in the general planetary science community.

2 Applicable Documents and Constraints

This Data Product SIS is consistent with the following Planetary Data System Documents:

1. Planetary Data System Standards Reference, Version 1.7.0, September 15, 2016.
2. PDS4 Data Dictionary – Abridged – Version 1.7.0.0, September 30, 2016.
3. PDS4 Information Model Specification, V.1.7.0.0, September 30, 2016.

This Data Product SIS is responsive to the following OSIRIS-REx documents:

4. OSIRIS-REx Science Data Management Plan, UA-PLN-9.4.4-004, May 2016.
5. OSIRIS-REx Science Processing and Operations Center and Planetary Data System Small Bodies Node Interface Control Document, UA-ICD-9.4.4-101, Rev 1.0 October 31, 2013.
6. SPOC – OVIRS Interface Control Document, UA-ICD-9.4.4-1004.

This Data Product SIS is consistent with the following OSIRIS-REx documents:

7. The OSIRIS-REx Visible and Near InfraRed Spectrometer (OVIRS): Spectral Maps of the Asteroid Benu, Reuter, D., et. al, Space Science Reviews, 2018.
8. OVIRS Housekeeping Conversion Document, Rev 1.0, 2018.
9. OSIRIS-REx Coordinate System for Benu, Version 2.0, January 14, 2016.

Finally, this SIS is meant to be consistent with the contract negotiated between the OSIRIS-REx Project and the Science Processing and Operations Center.

3 Relationships with Other Interfaces

Changes to the data products described in this SIS effect the following software, products or documents. Software, products or documents to be archived are indicated with an (A).

Table 3-1. Interface Relationships

Name	Type	Owner
SPOC Database Schema	Product	SPOC
OVIRS Calibration Data (A)	Product	SPOC
OVIRS Pixel Wavelength Map (A)	Product	SPOC
OVIRS Cal Spectral Data (A)	Product	SPOC
OVIRS Housekeeping Data (A)	Product	SPOC
OVIRS Pipeline Software	Software	SPOC
SPOC Archive Packager	Software	SPOC
OSIRIS-REx Science Data Management Plan (A)	Document	Project

4 Data Product Characteristics and Environment

4.1 Instrument Overview

The OSIRIS Visible and near-IR Spectrometer (OVIRS) is a point spectrometer with a 4-mrad field of view (FOV) that provides spectra over the wavelength range of 0.4 – 4.3 μm to map the visible and near infrared characteristics of the surface of the asteroid (101955) Benu. It employs wedged filters (also called a linear variable filter) to provide the spectrum. A wedged filter is a two-dimensional spectral filter in which the wavelength of transmitted light varies in a well-defined fashion with position along one of the spatial dimensions. The OVIRS design is based on the New Horizons LEISA instrument design [1], but with simplified optics and extended wavelength range.

Figure 1. The OVIRS Instrument

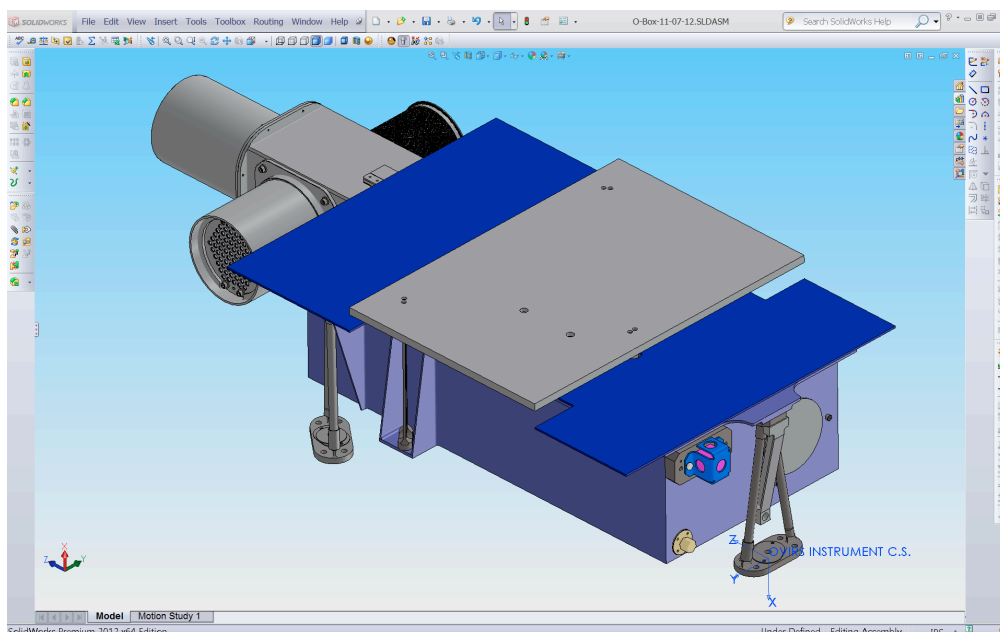

OVIRS spectra were required to be measured with a resolving power $R (= \lambda / \Delta\lambda)$ of greater than or equal to 125 in the 0.4 to $0.9 \pm 0.1 \mu\text{m}$ spectral band ($\Delta\lambda < 7.5 \text{ nm}$); R greater than or equal to 150 in the 1.0 ± 0.1 to $2.0 \pm 0.1 \mu\text{m}$ spectral band ($\Delta\lambda < 13 \text{ nm}$); and R greater than or equal to 200 in the 2.0 ± 0.1 to $4.0 \mu\text{m}$ spectral band ($\Delta\lambda < 22 \text{ nm}$). In addition, the spectral range from 2.9 to $3.6 \mu\text{m}$ is measured with R greater than or equal to 350 ($\Delta\lambda < 10 \text{ nm}$, $\Delta\nu < 10 \text{ cm}^{-1}$) to resolve key organic spectral features, such as those that have recently been observed on the asteroid 24 Themis ([2], [3]). A full description of the wavelengths can be found in Simon et al. 2018.

The OVIRS spectral ranges and resolving powers were optimized to provide surface maps of mineralogical and molecular components including carbonates, silicates, sulfates, oxides, adsorbed water and a wide range of organic species. As a point spectrometer, OVIRS operates in a scanning mode, in which the rotational motion of the asteroid is combined with slews of the spacecraft about the OVIRS scan axis to sample a region of interest and build up global maps. In the expected operational scenario, OVIRS will provide global spectral maps (20-m resolution), and spectra of the sample site (0.08 – 2-m resolution). OVIRS spectra will be used to identify volatile- and organic-rich regions. These data will be used in concert with data from the other OSIRIS-REx instruments to guide sample-site selection and provide an unprecedented global inventory of the composition and regolith structure of the asteroid Bennu’s surface.

OVIRS uses an off-axis parabolic (OAP) mirror to image the surface of the asteroid onto a field stop. The field stop selects a 4-milliradian angular region of the image. The light from this 4-milliradian area passes to a second OAP that recollimates it and illuminates the Focal Plane Assembly. Because the beam speed is low ($\sim f/50$) this assembly, consisting of the array with the filter mounted in close proximity to it, is effectively at a

pupil. Each detector element of the array “sees” the same spatial region of the asteroid but different columns of the array “see” it at different wavelengths. The complete spectrum of the 4-milliradian spot is obtained in a single measurement. This is somewhat different than the case for some wedged filter spectral imagers, such as LEISA, where the spectrum of a given point is built up over several frames, e.g., [1].

In order to obtain the high SNR required for OVIRS on a very dark asteroid surface (albedo ~3%), several (nominally 30) pixels will be averaged (superpixel) for each wavelength. The actual number of pixels summed will be determined in instrument testing.

The OVIRS observation profile is as follows:

Table 4-1. OVIRS Observation Profile

Mission Phase	Observation Campaign Description
<i>Outbound Cruise</i>	
	Instrument Check-out and Calibration (~every 6 months)
	Earth-Moon Flyby Observations
<i>Approach</i>	
	Full Disk Spectral Characterization
<i>Preliminary Survey</i>	
	Natural Satellite Spectral Characterization
<i>Detailed Survey</i>	
	Global Spectral mapping
	Dust and Gas Plume spectral Characterization
<i>Orbit A (1.5km)</i>	
	Solar and Internal Calibration
<i>Orbital B (1.0km)</i>	
	Solar and Internal Calibration
<i>Reconnaissance</i>	
	Sample Site Spectral Characterization
<i>TAG-Rehearsal</i>	
	Sample Collection Spectral Characterization

Mission Phase	Observation Campaign Description
<i>Sample Collection</i>	
	Sample Collection Spectral Characterization

4.1.1 Calibration Sources

The OVIRS instrument uses four in-flight calibration sources to track and adjust for instrument performance. Instrument operations are the same as imaging the target as for collecting any calibration source. The instrument data are identical for any calibration source and for imaging the target. The OVIRS data processing pipeline determines which calibration source is active. For scans that include both calibration data and target data separate Level-0 files will be produced for each source or signal (calibration or target). This will allow for the pipeline to adjust the calibration of target data using the companion calibration data.

1. **Deep Space** – Pointing the primary aperture at empty space to determine self-radiation, and detector signal offset.
2. **Solar Aperture** – Pointing the solar aperture towards the sun, while the primary aperture is pointing at empty space to determine any change in system response, using a well-known source (the sun) through the complete optical system.
3. **Filament Calibrator** – Pointing the primary aperture at empty space, while the powering the internal filament source to determine any change in detector and/or filter response from 0.5 μm – 4.0 μm
4. **Blackbody Calibrator** – Pointing the primary aperture at empty space, while the powering the internal blackbody source to determine any change in secondary mirror, detector and/or filter response from 2.3 μm – 4.3 μm .

4.1.2 Detector segmentation (Regions of Interest)

The OVIRS detector is covered by an array of Linear Variable Filters (LVF) that provide the collection of incoming light by wavelength. There are 5 filter segments, covering different wavelength ranges, and a covered segment to verify the detector response without direct illumination (dark response). To assure the best possible data quality and to reduce data volume “Regions of Interest (ROI)” are defined by the instrument team, programmed into the instrument, and only these sections of the detector are sampled. These ROIs can be changed in flight if it is determined that a new region of the detector and/or filter provides better performance. Nominally, the ROIs will remain stable throughout the life of the mission. The ROI configuration specifies the ROI and the number of superpixel lines contained in the ROI.

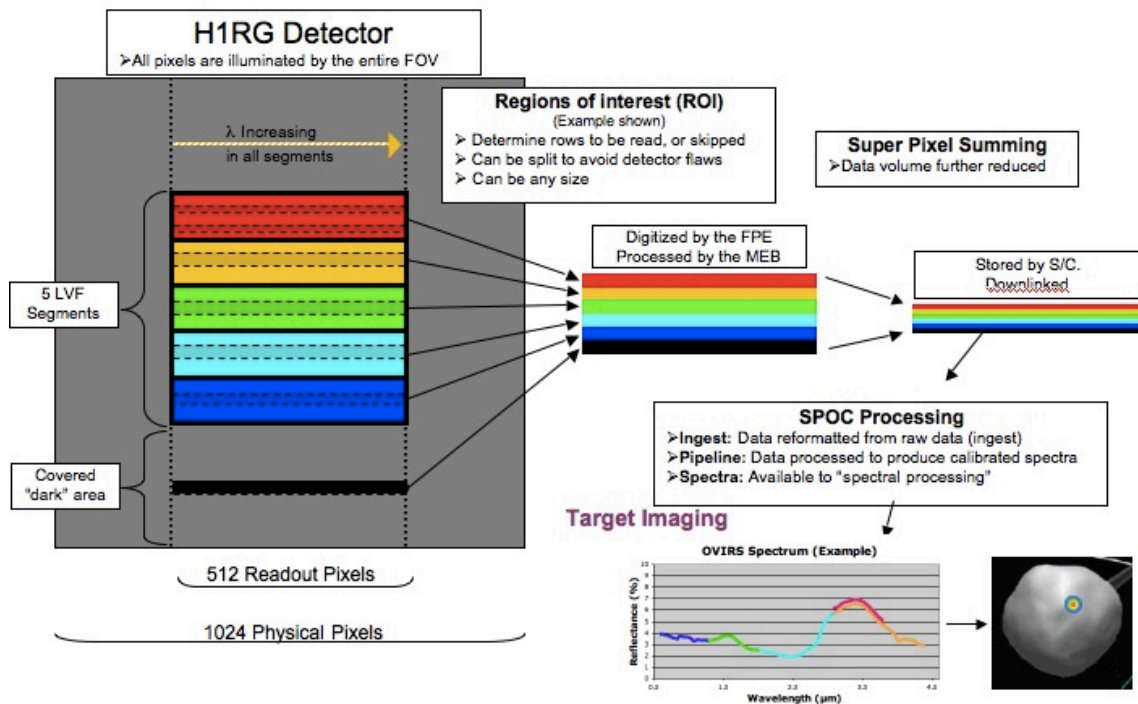

Figure 2. OVIRS Regions of Interest, and Modes

4.1.3 Data Processing Modes

The OVIRS detector is operated in Correlated Double Sampling (CDS) mode. That is, each pixel is sampled (16 bits) just after the signal from the previous integration is cleared (reset data), and sampled again after the pixel has integrated light for a period of time (integrated data). The difference between those values is the measure of integrated light on the pixel. OVIRS processes and outputs the CDS data in one of three modes (see Figure 2):

1. **Raw Mode** – The sampled ‘reset’ and ‘integrated’ values are maintained separately and output from the instrument.
2. **CDS Mode** – The sampled ‘reset’ and ‘integrated’ values are subtracted in the instrument, and the difference is output from the instrument.
3. **Normal Mode** – Subtracted ‘reset’ and ‘integrated’ values for several pixels of the same wavelength are summed together, and the sum, called a Super Pixel, (bit shifted to maintain 16 bits) is output from the instrument. In this mode, there is also the option to exclude pixels from the summing that are known to respond out-of-family and would corrupt the sum (through a Bad Pixel Map).

The “Normal” mode is the only mode designed to be part of the automated processing pipeline at the SPOC to be delivered to the PDS and is therefore the only mode formatted in detail in this document. Data in the CDS or Raw mode are for troubleshooting and/or

trending and are delivered only to the OVIRS instrument team in unprocessed format (Level 0) for analysis. Should science data be taken in any other mode than “Normal”, it will be processed on the ground to a “Normal” format and subsequently delivered to the PDS.

4.1.4 Data Formats

The OVIRS detector data are output as a packet structure, with one packet per Region of Interest. The SPOC Cal/Val process will reconstruct the packet data into the appropriate FITS format file. The SPOC is only responsible for processing OVIRS data in the Normal mode of operations.

4.2 Data Product Overview

Instrument data and processed spectral data are natively stored as binary Flexible Image Transport System (FITS) files. Spectra with associated meta-data are also stored in database tables in the OSIRIS-REx SPOC Data Repository for further processing by the SPOC systems. Housekeeping (HK) data are stored in the SPOC Data Repository and are written natively as binary tables. Calibration files necessary to process spectral data are stored as FITS files and are made available to the processing pipeline. The specific data products described by this SIS are:

1. OVIRS Raw Science Data (Level-0 data) – Raw instrument science data. Each level-0 file will be processed as a unit through the pipeline. Level-0 files are grouped by “science sequence” or dataset where a dataset is a group of contiguous frames with identical 11-bit ‘House Keeping Data’ fields [Table 4-3 (the grouping used by the CalVal pipeline)]. A dataset is either of calibration or target data. The instrument commanding will set the “House Keeping Data” field of the high-speed header which will indicate boundaries of each sequence. Individual instrument integrations within a sequence are known as frames.
2. OVIRS Raw Housekeeping Data (Level-0 data) – Housekeeping data stored in the SPOC database. A selection of HK fields is available for the data processing pipeline through the SPOC database. The Housekeeping data are delivered to the PDS as binary tables grouped by “science sequence”.
3. OVIRS Processed Housekeeping Data (Level-1 data) – Housekeeping data processed from digital number to physical unit stored in the SPOC database. HK fields are available for the data processing pipeline through the SPOC database. The Housekeeping data are delivered to the PDS as binary tables grouped by “science sequence”.
4. OVIRS Calibration Data – Data used by the pipeline to transform instrument data to science values. Calibration data files are provided by the OVIRS calibration team to the SPOC. The SPOC software provides the proper calibration data files to the automated pipeline.

These calibration files will be provided to the SPOC by the OVIRS instrument team in the FITS file format. The first delivery will be based on ground calibration. Updates will be made as necessary based on performance after launch.

- a. Bad Pixel Map – Map of total number of good pixels in each Super Pixel (512xL**x2).
 - b. Dark File – Default value to be subtracted from detector value, if no deep space is identified, else the local average is calculated for subtraction i.e. cal_dark array in L2 product (512xL).
 - c. Radiometric Correction File – Data to convert superpixel data to a characterized radiometric value (512xLx2), where there is a radiometric correction array for each instrument side (A=1, B=2). The radiometric correction arrays may be identical, for both sides but are not necessarily the same.
 - d. Out of Band Correction File – Data to correct radiometrically calibrated for out-of-band effects. (512xLx2), where there is an out of band correction array for each instrument side (A=1, B=2). The out of band correction arrays may be identical for both sides but are not necessarily the same.
 - e. On Board Calibrator File – Nominal OBC data to be compared with new observation. (512xL)
** Note: “L” is the number of superpixel lines in the ROI configuration.
5. OVIRS Calibrated Science Data (Level-2 data) – Instrument data that has been calibrated to radiance units. These data are stored as a 4-extension FITS file that includes calibrated instrument data, data quality, per frame wavelength assignments, and dark subtraction. Metadata contained in the FITS header and PDS XML label specify per frame geometry.

4.3 Data Processing

All OSIRIS-REx mission science data processing is performed at the University of Arizona Science Processing and Operations Center (SPOC). OVIRS science and housekeeping telemetry are received by the SPOC via the Lockheed Martin (LM) Mission Support Area (MSA) and the DSN. Instrument telemetry data are received from the Front-End Data System (FEDS), reconstructed, and stored in the SPOC data repository. Raw housekeeping data fields are converted to physical units and stored in the SPOC data repository. Raw data (Level 0) are retrieved from the data repository and fed into the OVIRS specific data processing pipeline. The pipeline produces calibrated OVIRS spectral data products.

Details about data format are specified later in section 5.

4.3.1 Data Processing Level

Table 4-2 shows the OSIRIS-REx data processing levels of all science data products described by this SIS. Correlation to NASA and CODMAC data processing levels and definitions can be found in Appendix 7.3. Calibration file data processing levels are not discussed, as calibration files require special production techniques.

Table 4-2. OVIRS Data Processing Levels

OVIRS Product	NASA Product Level	OSIRIS-REx Processing Level	Description
N/A	Packet data	N/A	OVIRS packets received on the ground containing instrument science telemetry.
Raw Science Data	Level-0	L0	Reformatted telemetry data stored in a format for use by the automated data processing pipeline.
Raw Housekeeping	Level-0	L0	Housekeeping data in DNs.
Processed Housekeeping	Level-1	L1	Housekeeping DNs converted to physical units.
Calibrated Science Data	Level -2	L2	Instrument data calibrated to radiance units.

4.3.2 Data Product Generation

All OSIRIS-REx science data processing is completed at the SPOC located at the University of Arizona. Data processing is centralized for all instruments to facilitate the relatively quick turn-around needed by the science and operations teams to make tactical decisions about sample site selection.

4.3.2.1 Level 0 – Raw Science and Housekeeping Data

OVIRS science and housekeeping telemetry are received from the DSN and passed through the LM MSA to the SPOC via the FEDS. The SPOC ingests, sorts, reconstructs and stores telemetry data as raw science observation data that includes science frame (integration) data, timing and spatial information and raw housekeeping as tables of values associated with time. The OVIRS instrument has three modes of operation: Raw, CDS and Normal resulting in three types of observational data. Header data in the telemetry stream will indicate the type of observational data. The OVIRS data processing pipeline will process only the Normal data type. Other data types are used only for trending and troubleshooting and are passed to the instrument team for processing or are converted to the Normal format and processed through the pipeline.

Figure 3. OVIRS Ingest/Digest Data Flow

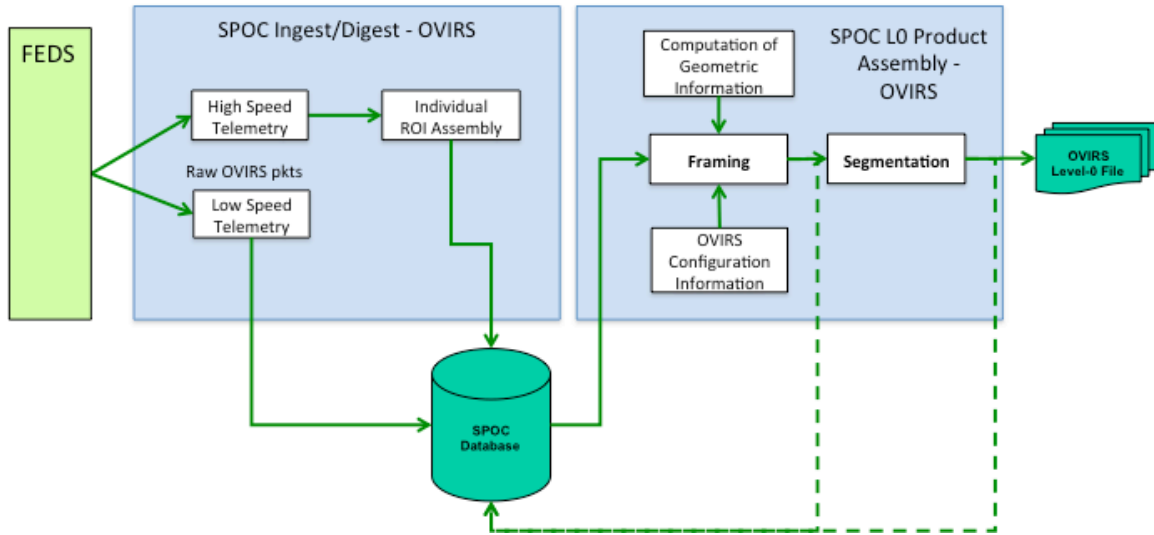

The SPOC Ingest processing software is responsible for two functions on the OVIRS science data:

1. **Framing** – Processing the raw OVIRS high-speed packets into a Level-0 science data file. The Level-0 files are FITS files with all integration frames of raw binary detector data as the primary data set and one FITS binary table extension containing the per frame header and spatial information. The data array shape depends on the number of super pixel lines in the ROI configuration, which must be known a priori. The SPOC will have a reference table provided by the OVIRS team to determine the ROI configuration from the code.
2. **Segmentation** – Identifying the portions of the OVIRS packets that will be processed together into a Level-0 file. Information in the OVIRS high-speed (science) packet header is intended to provide the information for Ingest to segment the packet stream into separate files. The field labeled “House Keeping Data” in the science telemetry data header is monitored. Any change in this 11-bit field triggers the creation of a new Level-0 file. The content of the field can be used to determine the target and instrument configuration, and to provide information in the file name. The bits of the “House Keeping Data” field are described in Table 4-3.

Table 4-3. OVIRS science telemetry data header “House Keeping Data” field definition

Bits Field	Value	Meaning
Bit 9-11	0-7	ROI Configuration (value 1 is the default science ROI)

Bits Field	Value	Meaning
Bit 8	0	Hold level-0 data for OVIRS team processing (non-science configuration)
Bit 8	1	Process data with SPOC pipeline.
Bit 4-7	0	Unspecified target
Bit 4-7	1	Viewing space with calibrators off
Bit 4-7	2	Blackbody calibrator on (viewing space)
Bit 4-7	3	Filament calibrator on (viewing space)
Bit 4-7	4	Blackbody and filament calibrators on (viewing space)
Bit 4-7	5	Solar calibrator viewing the sun, primary aperture viewing space
Bit 4-7	6	Primary aperture viewing Bennu
Bit 4-7	7	Primary aperture viewing an alternate target
Bit 1-3	0-7	Observation Sequence Counter

4.3.2.2 Level 1 – Processed Housekeeping Data

Raw housekeeping data that records instrument temperatures, voltages and currents is processed to convert the raw housekeeping digital number (DN) values into physical units (i.e. Volts, Celsius, Amps, etc.). Conversions are made using per housekeeping channel conversion polynomials and coefficients. The conversion polynomials and coefficients can be found in the OVIRS Housekeeping Conversion document. There is no Level-1 equivalent science data product, as conversion from DN to physical units requires more advanced processing than application of a single polynomial.

4.3.2.3 Level 2 – Calibrated Science Data

The SPOC automated software (Figure 4) will provide the OVIRS pipeline code Level-0 data files for the target observation, Level-1 housekeeping data, and the previous calibration and space observation files. In this context observations are the sequence of related (by science telemetry header) instrument integrations (also known as frames or spots). The pipeline code processes each observation separately to produce calibrated spectral data. The Calibration Files are pre-generated and supplied by the OVIRS team. In some mission phases, space view data are taken periodically during the target scans. The SPOC provides the pipeline code with the Level-0 file of the nearest dark-sky(space). “Nearest” is defined as the closest previous observation of that type [bits 4-7 == 1(space), 2(blackbody), or 3(filament)].

Calibration is performed as follows on each spectrum:

- The background level is subtracted, using the nearest space views
 - The closest block of the deep space data, acquired on the same instrument side, integration time, super pixel, and focal plane temperature, is identified
 - The first and last few spectra are discarded to avoid illuminated source contamination
 - Remaining spectra area screened for outliers, and averaged to produce background dark frame
 - The same background level is used for all spectra in the science block
- Calculate and remove out-of-band contribution
 - Convert long wavelength counts to photon radiance
 - Integrate photon radiance from 2.8 to 3.9 μm
 - Multiply sum by out-of-band coefficients for each pixel
 - Convert back to counts
 - Subtract out-of-band counts from background-subtracted spectrum
- Convert from counts to radiance units
 - Divide by exposure time to get counts/s
 - Multiply by radiometry coefficients for each pixel
- Screen for outliers (Due to cosmic rays or other noise)
 - For a given pixel, calculate the mean and standard deviations across the pixel's ROI column +/- 2 columns (5 columns total)
 - Compare each pixel in the central column to the mean, discard pixels 3-sigma from the mean (set to zero and note in data quality).
 - Iterate a maximum of three times, unless std. deviation is lower than the photon noise limit

The OVIRS automated pipeline produces calibrated data from OVIRS instrument data as described in the steps given above (and described further in the `ovirs_cal_doc.pdf` found in the calibrations collection and Simon et al. 2018). Cosmic-ray events are identified by analyzing the calibrated pixel values (now called outlier screening as described above). A cosmic-ray identified in a particular super pixel will cause that super pixel to be flagged. Calibrated pixel data, cosmic-ray identification, and bad pixel information are used to produce a quality flag (Table 4-4), and a noise estimate. At this point, the calibration process has converted DN to $\text{W}/\text{cm}^2/\text{sr}/\mu\text{m}$, for each super pixel. Values in the Level-2 files are $\text{W}/\text{cm}^2/\text{sr}/\mu\text{m}$. These are stored in the Level-2 data file as a 512 by L array where 512 is the number of detector columns and L is the number of super-pixel rows. This product can be thought of as L raw disjointed spectra, with some overlap where multiple filter segments cover the same wavelength range. These data are the base data for all other scientific analysis.

Table 4-4. OVIRS Quality Flag Description

Quality Bits	Description
0-3	Count id good pixels in superpixel (0-8 for SP=8)
4	Empty superpixel flag (1: no good pixels in superpixel)

Quality Bits	Description
5	Cosmic Ray Flag (No longer used)
6	Rejected Outlier Flag (1 for rejected)
7-31	Reserved for future use

Performance is monitored using solar, blackbody, and filament data and the calibration coefficients will be updated, as needed.

Figure 4. OVIRS Cal/Val Pipeline Invocation

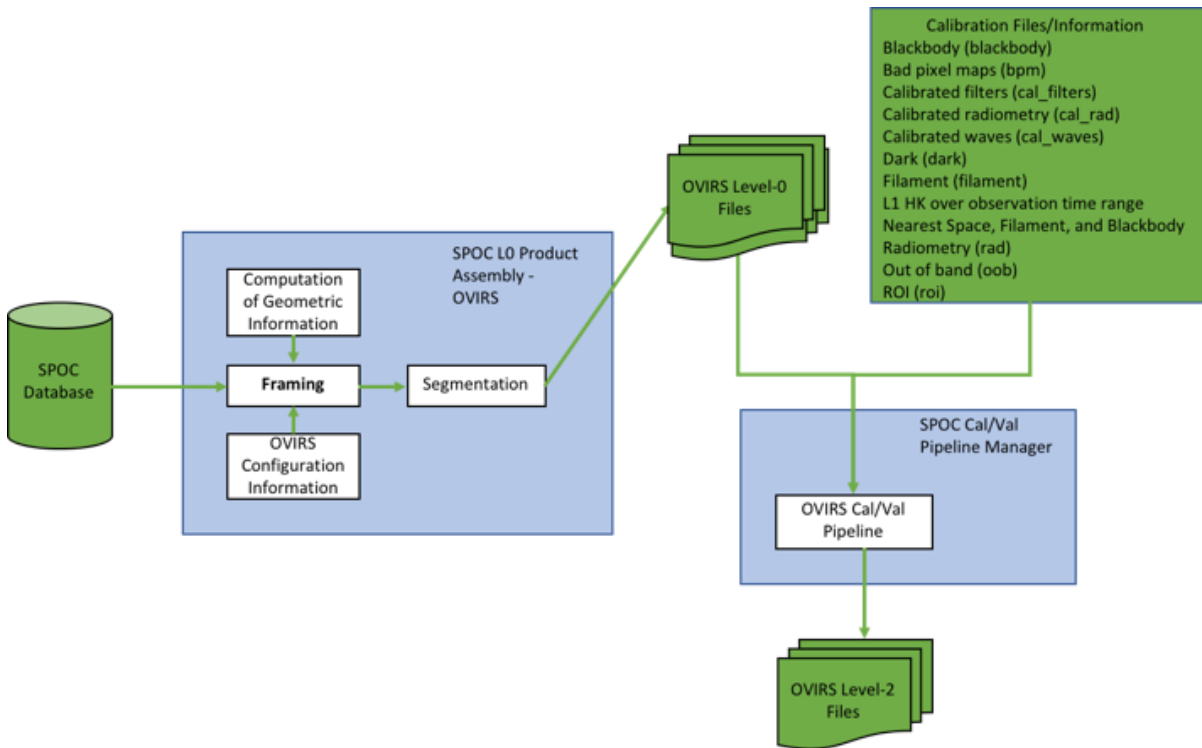

4.3.3 Data Flow

OVIRS un-calibrated and calibrated data products are built up in sequential data processing steps addressing specific corrections or calibrations. All data products are built from raw telemetry ingested into the SPOC data repository system. The OVIRS data processing pipeline is executed by the SPOC system, triggered by the arrival of new L0 science data. The SPOC system provides the pipeline with the necessary science data, calibration data, housekeeping, and S/C attitude data. Data products generated by the OVIRS pipeline are returned to the SPOC data repository for storage. The OSIRIS-REx Instrument and Science Teams access the data repository through a query tool.

Table 4-5 shows the expected OVIRS data collection by mission phase. The number of expected instrument frames are specified as well as the expected data volume of the processed data products. Number of frames are based on the OSIRIS-REx Design Reference Mission; actual number of frames and data volumes will be updated as mission phases are completed.

Table 4-5. OVIRS Data Products/ Volume by Mission Phase

Mission Phase	Launch	Cruise	App	Prelim Survey	Orbit A	Detail Survey	Orbit B	Recon	TAG Rehearsal	Sample Collection
OVIRS Frames	180	13440	177 20	0	120	11294 0	240	2004 0	2940	2525
OVIRS L0 (MB)	6	430	567	0	4	3614	8	641	94	81
OVIRS L0 HK (MB)	<5	<20	<5	0	<5	<25	<5	39	<6	<5
OVIRS L1 HK (MB)	<10	<40	<10	0	<10	<40	<10	<10	<10	<10
OVIRS L2 CAL SCI DATA (MB)	90	6720	886 0	0	60	56470	120	1002 0	1470	1262

It is possible that more than one version of observational data products may be produced during the initial calibrations if one or more calibration files needs to be updated. Re-processed data products are indicated with an incremented version number in the file name. It is not expected that data products will change once they have been delivered to the PDS. If an update to data products needs to be made after delivery to PDS, these products will be identified by an incremented version number in the filename and an incremented Version_ID in the PDS label. An errata file will be included in the document directory to explain the change. Previously released PDS products will be deprecated in the archive. Any changes to the data processing pipeline are configuration controlled and follow the standard OSIRIS-REx configuration control process. Re-processed spectra are identified in the filename (see Section 4.3.4) by and are noted as to why re-processing was necessary.

4.3.4 Labeling and Identification

All OVIRS products consist of a PDS4-compliant detached XML label that describes the content and format of the associated data files. Labels and products are associated by file name with the label having the same name as the data product except that the label file has an .xml extension.

Labels are constructed with the PDS4 Product Class, Product_Observational sub-class. The Product_Observational sub-class describes a set of information objects produced by an observing system. A hierarchical description of the contents of Product_Observational products is

Product_Observational

Identification_Area - attributes that identify and name an object

- Logical_Identifier - name/location of file that uniquely identifies the product in the PDS system
- Version_ID – PDS revision number of product
- Title - Name of file
- Information_model_version - version of PDS4 information model used to create product
- Product_Class - attribute provides the name of the product class (Product_Observational)
- Modification_History - attributes describing changes in data product

Observation_Area - attributes that provide information about the circumstances under which the data were collected.

- Time_Coordinates - time attributes of data product
- Primary_Results_Summary - high-level description of the types of products included in the collection or bundle
- Investigation_Area - mission, observing campaign or other coordinated, large-scale data acquisition attributes
- Observing_System - observing system (instrument) attributes
- Target_Identification - observation target attributes
- Mission_Area - mission specific attributes needed to describe data product

File_Area_Observational - describes a file and one or more tagged_data_objects contained within.

- File - identifies the file that contains one or more data objects
- Table_Binary - defines a simple binary table.

Information in the preceding paragraphs was distilled from the PDS4 Information Model provided by PDS. Additional information on product labels can be found at <https://pds.nasa.gov/pds4/about/index.shtml>.

OSIRIS-REx science data products are identified (named) according to the OSIRIS-REx Naming Conventions Document (UA-HBK-9.4.4-905). The following paragraphs are excerpts of this document that describe how OVIRS data products are named. The generalized file naming convention is:

Date/Time + “_” + Instrument + “_” + Product Type + “.” + PDS Type *

The Date/Time field has three variations for the range of product types.

Products that are collections of frames (instrument integrations) use a UTC date/time string ofYYYYMMDD”T”HHMMSS”S”FFF”, e.g.(20170922T231910S306, S306 portion of the time is the sub-second portion of the time). Housekeeping products that are collections of observations (multiple frame sets) are “daily” collections of all observations meaning from midnight to midnight of the day of interest. Products that are made of multiple observations that must be grouped, and span multiple days, use the date of the first observation in the sequence.

The **instrument** is one of the following:

Table 4-6. Instrument Abbreviations

Abbreviation	Instrument Name
ocm	OCAMS
pol	PolyCam
map	MapCam
sam	SamCam
ncm	NavCam
nft	NFT
stw	StowCam
ola	OLA
ote	OTES
ovr	OVIRS
rex	REXIS
sxm	REXIS Solar-X-Ray Monitor

The **product type** is code for the kind of product found in the data file. The product types for OVIRS are:

Table 4-7. OVIRS Product Type

Product Type	Definition
unknown	Unknown instrument configuration
blackbody	Black body calibration data
space	Deep space calibration data
filament	Filament calibration data
blackbodyplusfilament	Filament plus black body calibration
sun	Solar calibration data
scil0	Level 0 Science Data Product
hkl0	Level-0 Housekeeping
hkl1	Level-1 Housekeeping
scil2	Radiometrically Calibrated Spectral Data

The **PDS type** file suffix indicates the type of data product file.

An example files name for a single product as it makes its way through the data processing pipeline are:

20161014T021147S831_ovr_scil0.fits
 20161014T021147S831_ovr_scil0.xml
 20161014T021147S831_ovr_scil2.fits
 20161014T021147S831_ovr_scil2.xml

The PDS type file suffix indicates the type of file of the data product. OVIRS data products have three types of suffixes: .fits for science data, .dat for binary tables and .xml for labels. All OVIRS files are created with detached PDS labels. The labels are PDS compliant XML format labels. Examples of labels can be found in Section 7.4.

OVIRS calibration files are named according to the following convention:

Instrument(3) + “_” + Calibration_Type + “_” + “Detector”+ “.” + PDS Type(3)

Where instrument is ovr for OVIRS, and Calibration Type and Detector are defined by the following tables.

Table 4-8. OVIRS Calibration Type

Calibration Type	Definition
bpm	bad pixel map
rad	radiometric conversion data
oob	out of band signal information

Table 4-9. OVIRS Calibration File Detector Values.

Layout	Definition	Array Layout
S1a	Superpixel data	512 x 23 x N
S2a	Superpixel data	512 x 78 x N
F1a	Filter data	5 x N
C1a	ROI configuration data	7 x N
D1a	Full detector data	512 x 1024 x N
B1a	Spectral binned data	1393 x N

Note that “Detector” is a misnomer for this field in the OVIRS calibration naming scheme. For OVIRS this field is used to indicate the size and shape of the data array.

Capitalization in filenames is not significant. For OSIRIS-REx, Logical Identifiers (LIDS) are formed using the filename as the product_id. Any discrepancy in case between the actual filename and the LID is not significant and should be treated as the same name. In early OVIRS PDS releases prior to encounter data, it is possible that file names will include a version number prior to the file type suffix. This version number is an internal version number and should be disregarded.

4.4 Standards Used in Generating Data Products

4.4.1 PDS Standards

All data products described in this SIS conform to PDS4 standards as described in the PDS Standards document noted in the Applicable Documents section of this SIS. Prior to public release, all data products will have passed both a data product format PDS peer review and a data product production pipeline PDS peer review to ensure compliance with applicable standards.

4.4.2 Time Standards

Time Standards used by the OSIRIS-REx mission conform to PDS time standards. The spacecraft clock (SCLK) reference is 1/1/2000 12:00:00 UTC, with a minimum range date from 1/1/2010 to 1/1/2030. Onboard time tagging is the standard 32-bit seconds and 16-bit subseconds. The spacecraft clock string reported in various data products contains the spacecraft clock partition at a number before a slash as well as the seconds dot subseconds, e.g. 3/0545586959.34560. It is possible that the seconds portion of the sclk string at the beginning of a science sequence may be noticeably small (seconds <100), this is due to data collections prior to an instrument - spacecraft clock time synchronization. All OSIRIS-REx data products contain both the spacecraft clock time (SCLK) of data acquisition and a conversion to UTC to facilitate comparison of data products. In the case of OVIRS spacecraft clock time is given at the mid-frame time of the acquisition. Products also contain Ephemeris Time (ET) at the mid-frame time to facilitate processing.

4.4.3 Coordinate Systems

All coordinate systems used by the OSIRIS-REx mission conform to IAU standards. A complete discussion of the coordinate systems and how they are deployed in the mission can be found in the document “OSIRIS-REx Coordinate System for Bennu” found in the OSIRIS-REx mission bundle documents collection. For reference, latitude and longitude are planetocentric with no adjustment for non-spherical shape.

4.4.4 Data Storage Conventions

OVIRS L0 and L2 FITS data products conform to the FITS 4.0 standard (https://fits.gsfc.nasa.gov/standard40/fits_standard40aa.pdf), and contain the necessary headers and keywords to allow users to interrogate data products with any standard FITS reader. Text products conform to UTF-8 encoding. L0 and L1 Binary table products are stored as MSB.

4.5 Data Validation

The SPOC has a comprehensive Verification and Validation Plan for all software used at or developed by the SPOC. All software is configuration controlled and any changes made follow the SPOC Configuration Control Plan, which includes substantive testing of changes. During day-to-day production of L0 data products from telemetry, check sums and spot checks are used to validate that software is producing data products correctly.

In addition to software verification and validation, all OSIRIS-REx data product types have been peer reviewed for both PDS data format acceptability and scientific usefulness. No changes are expected to data formats after peer review. The SPOC Configuration Control Plan governs any changes, should they be needed.

When data are prepared for submission to the PDS, both the OVIRS and SPOC Teams will use PDS / mission-provided validation tools for conformance to the PDS4 standards. Scientific validation of the data contained within the OVIRS data products will, however, occur as a manual process after all automated software checks have been completed.

5 Detailed Data Product Specifications

The following sections provide detailed specifications for each OVIRS data product. These specifications will provide sufficient detail, so that users can read and interpret the products.

5.1 Data Product Structure and Organization

The OSIRIS-REx archive is organized into bundles for each instrument/detector (OCAMS, OTES, OVIRS, OLA, REXIS), TAGSAM, SPICE, DSN, bundles for each discipline specific set of higher-order data products, and a mission bundle with mission-wide context and schema information. Each bundle will contain data collections for each data processing level of each data type. Collections will be sub-divided by time interval (mission phase). Each PDS bundle also contains a document collection, to provide the appropriate ancillary information to properly interpret and use the data.

All OVIRS data products are structured as Flexible Image Transfer System (FITS) files or Binary Table files. OVIRS data products are organized by type and data processing level (l0sci, l2sci, l0hk and l1hk) and then by mission phase. Valid mission phases include CRUISE1, EGA, CRUISE2, APPROACH, PRELIM SURVEY, DETAIL SURVEY, ORBIT A, ORBIT B, RECON, REHEARSAL, and TAG. As instrument observation sequences are planned to support sample site selection and sample collection activities, not all instruments collect data in all mission phases. In these cases, there will be no data products for that instrument assigned to the mission phase.

The OVIRS bundle directory structure is as follows:

```
orex.ovirs
  data_hkl0 – raw level 0 housekeeping
    cruise_1
    ega
    cruise_2
    approach
    preliminary survey
    orbital a,
    detailed survey
    orbital b
    reconnaissance
    rehearsal
```

TAG (Touch-and-go)
data_hkl1 – reduced level 1 housekeeping
 cruise_1
 ega
 cruise_2
 approach
 preliminary survey
 orbital a,
 detailed survey
 orbital b
 reconnaissance
 rehearsal
TAG (Touch-and-go)
data_raw – level 0 raw spectral data products
 cruise_1
 ega
 cruise_2
 approach
 preliminary survey
 orbital a,
 detailed survey
 orbital b
 reconnaissance
 rehearsal
TAG (Touch-and-go)
data_calibrated – level 2 calibrated spectral data products
 cruise_1
 ega
 cruise_2
 approach
 preliminary survey
 orbital a,
 detailed survey
 orbital b
 reconnaissance
 rehearsal
TAG (Touch-and-go)
calibration – OVIRS calibration files
document – OVIRS documentation

5.2 Data Format Descriptions

5.2.1 OVIRS L0 Science Data

The OVIRS L0 science data product is formatted natively as a 2 extension FITS file. The primary data unit is a 3-d cube of OVIRS science data with format 512xROIxFrames,

where 512 is the number of pixels in the detector row, ROI is number of super pixel lines in the ROIs, and frames are number of frames (instrument integrations) in the observation sequence. The second data unit is a binary table of the geometry and header information for each frame (plane) of the 3-d cube. The science data (primary data unit) and binary table information (secondary data unit) correspond by number, i.e. the first entry in the binary table corresponds to the first frame in the primary science data. Level 2 calibrated radiance data products can be matched to Frames with identical mid_obs_sclk time in binary table.

In PDS labeling terms, the OVIRS L0 Science product is formatted as a last index fastest Array_3d_Image, where frames are the number of instrument integrations in the observation sequence, lines are the number of super pixel lines in the ROIs, and samples are the number of pixels in the detector row (always 512) with an appended Table_Binary that contains the metadata for each frame. Row 1 of the binary table corresponds to Frame 1 of the array.

Table 5-1. OVIRS L0 Science Data Product –Primary Data Unit/Array_3d_Image

Attribute Name	FITS Keyword	Units	Description
element_array.data_type	BITPIX		number of bits per data pixel (16 for L0)
axes	NAXIS		number of data axes
axis_array.sequence_number	NAXIS1		Length of FITS data axis 1 equivalent to sample. Detector pixels (512)
axis_array.sequence_number	NAXIS2		Length of FITS data axis 2 equivalent to line. Number of lines in ROI
axis_array.sequence_number	NAXIS3		Length of FITS data axis 3 equivalent to frames. Number of frames in science sequence.
n/a - FITS specific	EXTEND		FITS dataset may contain extensions
element_array.value_offset	BZERO		offset data range to that of unsigned short
element_array.scaling_factor	BSCALE		default scaling factor
investigation_area.name	MISSION		Mission name: OSIRIS-REx
observing_system.name	HOSTNAME		Spacecraft hostname
observing_system.component.name	INSTRUME		Instrument name: OSIRIS-REx OVIRS

Attribute Name	FITS Keyword	Units	Description
n/a - FITS Specific	ORIGIN		University of Arizona Science Processing and Operations Center
mission_area.start_date	OBSSTART		Coordinated Universal Time of the first frame in the science sequence
mission_area.stop_date	OBSEND		Coordinated Universal Time of the last frame in the science sequence
mission_area.start_sclk	SCLKSTRT		SCLK Time (#/SSSSSSSSSS.sssss) of the first frame in the science sequence
mission_area.stop_sclk	SCLKEND		SCLK Time (#/SSSSSSSSSS.sssss) of the last record in the science sequence
mission_area.obs_target_x	OBS TARG		Observation Target Type ID: 0 - Unknown, 1 - Space, 2 - Blackbody calibration, 3 - Filament, 4 - Blackbody + Filament, 5 - Sun, 6 - Bennu, 7 - Other
mission_area.roi_data	n/a		Array_3D_Image: (Last index fastest) Frames by ROI Lines by Detector Samples (512). Note that FITS files are first index fastest.

Table 5-2. OVIRS L0 Science Data Products – Secondary Data Unit/Table Binary. Note that the first record of this table corresponds to the first frame of data in the primary data unit.Array_3d_Image (Table 5-1).

Binary Table Column Name	Start Byte	Data type	Units	Description
mid_obs_sclk	1	ASCII_String		The SCLK string of the mid-exposure time, mid_obs
bore_flag	21	UnsignedByte		Boresight flag 0-Boresight does not intersect surface of asteroid; 1-Boresight

Binary Table Column Name	Start Byte	Data type	Units	Description
				intersects surface of asteroid
fov_fill_flag	22	UnsignedByte		Field of view flag 0- Entire FOV images empty space; 1-Entire FOV image s asteroid surface; 2-Portion of FOV images empty space
bore_angle	23	IEEE745MSB Double	deg	Angle between boresight and origin of Bennu in planetocentric Cartesian coordinates
latitude	31	IEEE745MSB Double	deg	Planetocentric latitude of boresight intersection with the surface. Allowed range +90.0 to -90.0. If Boresight Flag NE 1, then value shall be 0.0
longitude	39	IEEE745MSB Double	deg	Planetocentric longitude of boresight intersection with the surface. Allowed range 0 to 360. If Boresight Flag NE 1, then value shall be 0.0
range	47	IEEE745MSB Double	km	Range from S/C to boresight intersection
boresight_x	55	IEEE745MSB Double	m	X coordinate of boresight intersection with surface in planetocentric Cartesian coordinates. Allowed range 0 to 1000.0. If Boresight Flag is not equal to 1, then value shall be -9999.
boresight_y	63	IEEE745MSB Double	m	Y coordinate of boresight intersection with surface in planetocentric Cartesian coordinates. Allowed range 0 to 1000.0. If

Binary Table Column Name	Start Byte	Data type	Units	Description
				Boresight Flag NE 1, then value shall be -9999
boresight_z	71	IEEE745MSB Double	m	Z coordinate of boresight intersection with surface in planetocentric Cartesian coordinates. Allowed range 0 to 1000.0. If Boresight Flag NE 1, then value shall be -9999
incidence_angle	79	IEEE745MSB Double	deg	Incidence angle. The angle between the vector normal to the surface at the location of the boresight intersection with the surface and the vector pointing at the Sun. If Boresight Flag NE 1, then value shall be 0.0. Allowed range is 0.0 to 90.0
emission_angle	87	IEEE745MSB Double	deg	Emission angle. The angle between the vector normal to the surface at the location of the boresight intersection with the surface and the vector pointing to the Spacecraft. If Boresight Flag NE 1, then value shall be 0.0. Allowed range is 0.0 to 90.0
phase_angle	95	IEEE745MSB Double	deg	Phase Angle. The angle between the vector pointing to the Sun and the vector pointing to the Spacecraft. If Boresight Flag NE 1, then value shall be 0.0. Allowed range is 0.0 to 180.0
fov_fill_factor	103	IEEE745MSB Double	frac	Fill Factor. If FOV Flag = 2, describes the fraction of the FOV that

Binary Table Column Name	Start Byte	Data type	Units	Description
				intersects the asteroid surface. If FOV Flag = 0, value shall be 0.0. If FOV Flag = 1, value shall be 1.0. Allowed range is 0.0 to 1.0
semimajor_axis	111	IEEE745MSB Double	m	Semi-major axis of FOV ellipse on surface
semiminor_axis	119	IEEE745MSB Double	m	Semi-minor axis of FOV ellipse on surface
sun_range	127	IEEE745MSB Double	km	Range from Sun to center of Bennu
target_range	135	IEEE745MSB Double	km	Range from S/C to target body center
right_ascension	143	IEEE745MSB Double	deg	Boresight Right Ascension (RA) in J2000 frame
declination	151	IEEE745MSB Double	deg	Boresight Declination (DEC) in J2000 frame
bennu_ra	159	IEEE745MSB Double	deg	Right Ascension of the vector, expressed in the Earth Mean Equator of the J2000 Epoch, from the ORX spacecraft toward the target named in FITS keyword BENNURDT (typically Bennu); see also BENNURDQ for a statement of the quality of this value
bennu_dec	167	IEEE745MSB Double	deg	Declination of the vector, expressed in the Earth Mean Equator of the J2000 Epoch, from the ORX spacecraft toward the target named in FITS keyword BENNURDT (typically Bennu); see also BENNURDQ for a statement of the quality of this value

Binary Table Column Name	Start Byte	Data type	Units	Description
bennu radec target	175	ASCII String		Target for the BENNURA, BENNUDEC, BENNUNX1 and BENNUNX2 FTIS keywords; typically BENNU; may be NONE if the calculation failed. Target is not required to be in the field of view.
bennu radec quality	207	ASCII String		(Quality: provenance) for the BENNURA, BENNUDEC, BENNUNX1, BENNUNX2 FITS keywords. This will be one of three values: (BEST: SPK), meaning the geometry was obtained from SPICE SP-Kernels; (POOR: osculating elements; +/- 1E6km), meaning the geometry was obtained from osculating orbital elements of Bennu w.r.t the Sun, and will have uncertainties of order 1E6km; (NONE: FAILURE), meaning both the SPK and elements methods failed; the parentheses, (), are only delimiters here and not part of the quality:provenance values.
utc	247	ASCII String		The UTC time of the instrument clock on readout
mid_obs	271	ASCII String		Spacecraft mid-exposure time, UTC [Cal d]

Binary Table Column Name	Start Byte	Data type	Units	Description
				(DATE_OBS - .5*EXPTIME).
expo_ms	295	IEEE745MSB Double	ms	Exposure time in milliseconds
exposure	303	IEEE745MSB Double	s	Exposure time in seconds
mid_obs_et	311	IEEE745MSB Double	s	The ephemeris time of the mid-exposure time, mid_obs
meta_ker	319	ASCII String		Metakernel for SPICE processing
roi_cfg	383	UnsignedByte		ROI Configuration ID
roi_mask	384	UnsignedByte		Bit-wise ROI contains corrupted data, which caused the CRC error
roi_mask	385	UnsignedByte		Bit-wise ROI present
auto_process	386	UnsignedByte		Auto Process Flag: if set, SPOC may rely on the data field integrity and produce Level 1 and Level 2 data
test_pattern	387	UnsignedByte		0 = real data, Non-zero = particular test pattern
processing_type	388	UnsignedByte		0 = Raw data, 1 = Correlated Double Sampling, 2 = Normal
obs_target	389	UnsignedByte		Observation Target ID: 0 - Unknown, 1 - Space, 2 - Blackbody calibration, 3 - Filament, 4 - Blackbody + Filament, 5 - Sun, 6 - Bennu, 7 - Other
obs_counter	390	UnsignedByte		Observation Counter: useful for tracking data back to the command load and the pointing definition.
sequence_count	391	UnsignedByte		Rollover counter; sequence count for the science packet for the frame

Binary Table Column Name	Start Byte	Data type	Units	Description
timestamp	392	UnsignedMSB 4		Number of seconds since the instrument was powered up. The time stamp indicating when the packet was formed. Note: lower 4 bits have 0.1 second resolution, while the remaining 28 bits have 1 sec resolution per count.

5.2.2 OVIRS L2 CALIBRATED SCIENCE DATA

The OVIRS L2 calibrated science data product is a 5-extension FITS file. The primary data unit contains an array of radiance values for each super pixel line in the ROI for a single frame (instrument integration). Metadata in the primary FITS header and the PDS

Figure 5. Wavelength Array Diagram

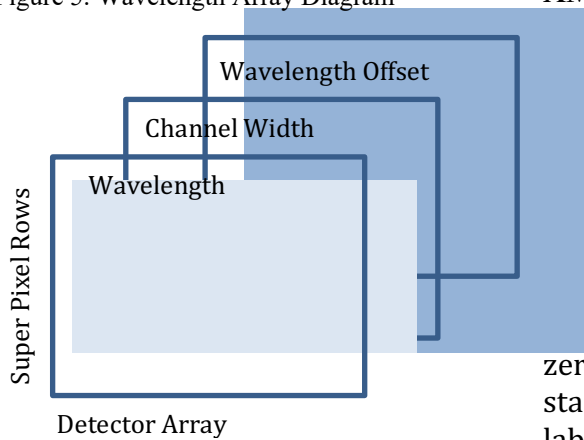

XML label give the timing and spatial information for that frame. The second FITS header data unit (HDU) gives the data quality for each radiance value. The third FITS HDU is a 3-d array of the wavelengths associated with the radiances where Plane 1 of the cube is the wavelengths, Plane 2 is the channel width, and Plane 3 is the wavelength offset based on detector temperature (this may be very close to zero). To be compliant with PDS4 standards, the wavelength array is labeled in the PDS XML label as a set of

three 2-d arrays. In either case, the information contained in the arrays is identical. The fourth FITS HDU and sixth PDS XML array is the calibration dark array. These are the actual dark values subtracted from the L0 science product before conversion to radiance units. The final FITS HDU and PDS XML array is the noise array. This array is calculated as the $\sqrt{\text{signal} + \text{std dev of noise frame}^2}$, in radiance units.

The data contained in the OVIRS L2 calibrated science product is the data for a single instrument measurement that corresponds to single spot in the surface of Bennu (or other target). This data can be combined to produce a single spectrum. The data can be related back to a raw L0 data product by filename time, however this is not a one to one correspondence. The L0 products contain many spots and can be correlated to the L2 product by looking for the L0 product with the closest earlier time (i.e. time before) to that of the L2 product. The specific frames of L0 data that correspond to the L2 product have the identical mid_obs_sclk time. The

calibration files used in the processing of the L2 calibrated science product are noted in the reference list portion of the .XML PDS label.

Table 5-3. OVIRS Calibrated Science Data Format

Attribute Name	FITS Keyword	Units	Description
element_array.data_type	BITPIX		number of bits per data pixel
axes	NAXIS		number of data axes in array
axis_array.sequence_number	NAXIS1		Length of FITS data axis 1 equivalent to sample. Detector pixels (512)
axis_array.sequence_number	NAXIS2		Length of FITS data axis 2 equivalent to line. Number of lines in ROI
axis_array.sequence_number	NAXIS3		Length of FITS data axis 3 equivalent to frames. Number of frames in observation sequence. If absent, the array is a 2d-array representing a single frame's data.
n/a - FITS specific	EXTEND		FITS dataset may contain extensions
element_array.value_offset	BZERO		offset data range to that of unsigned short
element_array.scaling_factor	BSCALE		default scaling factor
investigation_area.name	MISSION		Mission name: OSIRIS-REx
observing_system.name	HOSTNAME		Spacecraft hostname
observing_system.component.name	INSTRUME		Instrument name: OSIRIS-REx OVIRS
mission_area.utc	DATE_OBS		The UTC time of the instrument clock on readout
mission_area.mid_obs	MIDOB		Spacecraft mid-exposure time, UTC [Cal d] (DATE_OBS - .5*EXPTIME).
mission_area.expo_ms	EXPTIME	ms	Exposure time in milliseconds
mission_area.exposure	EXPOSEC	s	Exposure time in seconds
mission_area.mid_obs_et	ET		The ephemeris time of the mid-exposure time, mid_obs
mission_area.mid_obs_sclk	MID_SCLK		The SCLK string of the mid-exposure time, mid_obs
mission_area.rad_fname	RADCOEF		Name of Radiance calibration file
mission_area.oob_fname	OOB		Name of Out of Band calibration file
mission_area.boresight_flag	BS_FLAG		Boresight flag: 0-Boresight does not intersect surface of asteroid; 1-Boresight intersects surface of asteroid
mission_area.fov_fill_flag	FOV_FLAG		Field of view flag: 0-Entire FOV images empty space; 1-Entire FOV image s asteroid surface; 2-Portion of FOV images empty space
mission_area.boresight_angle	BS_ANGLE	deg	Angle between boresight and origin of Bennu in planetocentric Cartesian coordinates
mission_area.latitude	LAT	deg	Planetocentric latitude of boresight intersection with the surface. Allowed range +90.0 to -90.0. If Boresight Flag is not equal to 1, then value shall be -9999.

Attribute Name	FITS Keyword	Units	Description
mission_area.longitude	LON	deg	Planetocentric longitude of boresight intersection with the surface. Allowed range 0 to 360. If Boresight Flag is not equal to 1, then value shall be -9999.
mission_area.boresight_range	RANGE	km	Range from spacecraft to the closest boresight intersection to spacecraft. Must be positive number. If Boresight Flag is not equal to 1, then value shall be -9999.
mission_area.boresight_x	BS_X	km	X coordinate of boresight intersection with surface in planetocentric Cartesian coordinates. Allowed range 0 to 1000.0. If Boresight Flag is not equal to 1, then value shall be -9999.
mission_area.boresight_y	BS_Y	km	Y coordinate of boresight intersection with surface in planetocentric Cartesian coordinates. Allowed range 0 to 1000.0. If Boresight Flag is not equal to 1, then value shall be -9999.
mission_area.boresight_z	BS_Z	km	Z coordinate of boresight intersection with surface in planetocentric Cartesian coordinates. Allowed range 0 to 1000.0. If Boresight Flag is not equal to 1, then value shall be -9999.
mission_area.incidence_angle	INCIDANG	deg	Incidence angle. The angle between the vector normal to the surface at the location of the boresight intersection with the surface and the vector pointing at the Sun. If Boresight Flag is not equal to 1, then value shall be -9999. Allowed range is 0.0 to 90.0
mission_area.emission_angle	EMISSANG	deg	Emission angle. The angle between the vector normal to the surface at the location of the boresight intersection with the surface and the vector pointing to the Spacecraft. If Boresight Flag NE 1, then value shall be -9999. Allowed range is 0.0 to 90.0
mission_area.phase_angle	PHASEANG	deg	Phase Angle. The angle between the vector pointing to the Sun and the vector pointing to the Spacecraft. If Boresight Flag is not equal to 1, then value shall be -9999. Allowed range is 0.0 to 180.0
mission_area.fov_fill_factor	FILL_FAC	frac	Fill Factor. If FOV Flag = 2, describes the fraction of the FOV that intersects the asteroid surface. If FOV Flag = 0, value shall be 0.0. If FOV Flag = 1, value shall be 1.0. Allowed range is 0.0 to 1.0
mission_area.semimajor_axis	SMJAX	m	Semi-major axis of FOV ellipse on surface
mission_area.semiminor_axis	SMNAX	m	Semi-minor axis of FOV ellipse on surface
mission_area.sun_range	SUN_RNG	km	Range from Sun to center of target body
mission_area.target_range	TRGTRNG	km	Range from S/C to target body center
mission_area.right_ascension	RA	deg	Boresight Right Ascension (RA) in J2000 frame.

Attribute Name	FITS Keyword	Units	Description
mission_area.declination	DEC	deg	Boresight Declination (DEC) in J2000 frame
mission_area.bennu_ra	BENNURA	deg	Right Ascension of the vector, expressed in the Earth Mean Equator of the J2000 Epoch, from the ORX spacecraft toward the target named in FITS keyword BENNURDT (typically Bennu); see also BENNURDQ for a statement of the quality of this value
mission_area.bennu_dec	BENNUDEC	deg	Declination of the vector, expressed in the Earth Mean Equator of the J2000 Epoch, from the ORX spacecraft toward the target named in FITS keyword BENNURDT (typically Bennu); see also BENNURDQ for a statement of the quality of this value
mission_area.bennu_radec_target	BENNURDT		Target for the BENNURA, BENNUDEC, BENNUNX1 and BENNUNX2 FITS keywords; typically BENNU; may be NONE if the calculation failed. Target is not required to be in the field of view.
mission_area.bennu_radec_quality	BENNURDQ		(Quality: provenance) for the BENNURA, BENNUDEC, BENNUNX1, BENNUNX2 FITS keywords. This will be one of three values: (BEST: SPK), meaning the geometry was obtained from SPICE SP-Kernels; (POOR: osculating elements; +/- 1E6km), meaning the geometry was obtained from osculating orbital elements of Bennu w.r.t the Sun, and will have uncertainties of order 1E6km; (NONE: FAILURE), meaning both the SPK and elements methods failed; the parentheses, (), are only delimiters here and not part of the quality:provenance values.
mission_area.meta_ker	META KER		Metakernel for SPICE processing
mission_area.fpa_moly_a_temp_x	n/a	degC	Detector temperature
array_2d_spectrum.calibrated			Array: Calibrated radiance values of frame
array_2d.quality			Array: Quality indicator of the calibrated frame
array_2d.center_wavelength			Array: Plane 1 of FITS 3d-Wavelength Array, center wavelengths
array_2d.channel_width			Array: Plane 2 of FITS 3d-Wavelength Array, channel widths
array_2d.temperature_dependence			Array: Plane 3 of FITS 3d-Wavelength Array, temperature dependence
array_2d.cal_dark			Array: Dark values subtracted from L0 science product before conversion to radiance.
Array_2d.noise			Array: Noise/uncertainty array calculated as $\sqrt{\text{signal} + \text{std dev of noise frame}^2}$, in radiance units

5.2.3 OVIRS L0 HOUSEKEEPING

The OVIRS L0 housekeeping data product is a 126-field binary table with a total width of 221 bytes. All L0 hk is recorded in digital numbers (DN). OVIRS hk measurements are taken every 1 second during instrument power on. There is one table row per measurement. This cadence can be reduced by command, but not increased. The 1 second cadence will be used in most operational activities. PDS data products group the hk observations together per science sequence or per Earth day in order to have manageable file sizes.

Table 5-4. OVIRS L0 Housekeeping

Field Num	Name	Field Location	Field Length	Data Type	Units	Description
1	idp_sync	0	4	UnsignedMSB4		Synchronization Pattern
2	idp_ccsds_ver	4	1	UnsignedByte		CCSDS Packet Version
3	idp_ccsds_type	5	1	UnsignedByte		CCSDS Packet Type
4	idp_ccsds_sec_flag	6	1	UnsignedByte		CCSDS Secondary Header Flag
5	idp_ccsds_apid	7	2	UnsignedMSB2		Packet ID, Data Product Identifier
6	idp_ccsds_grp_flags	9	1	UnsignedByte		Grouping flags
7	idp_ccsds_seq_cnt	10	2	UnsignedMSB2		Number of times this packet has been sent
8	idp_ccsds_pkt_len	12	2	UnsignedMSB2		Number of bytes following this field - 1
9	idp_ccsds_timestamp	14	4	UnsignedMSB4		Timestamp (MET coarse counter)
10	udp_ip_rcv_cnt	18	1	UnsignedByte		Number of UDP/IP packets received
11	udp_ip_err_cnt	19	1	UnsignedByte		Number of invalid UDP/IP packets received
12	sc_time_stat_cnt	20	1	UnsignedByte		Number of SC Time and Status Messages received
13	pps_cnt	21	1	UnsignedByte		Number of PPS (pulse per second) pulses received
14	edac_sram_sngl_st	22	1	UnsignedByte		SRAM single-bit error status
15	edac_sram_dbl_st	23	1	UnsignedByte		SRAM multi-bit error status
16	edac_mram_sngl_st	24	1	UnsignedByte		MRAM single-bit error status
17	edac_mram_dbl_st	25	1	UnsignedByte		MRAM multi-bit error status
18	op_mode	26	1	UnsignedByte		Software Mode
19	uart_status	27	1	UnsignedByte		Status register for UART (universal asynchronous receiver-transmitter)
20	wdt_count	28	1	UnsignedByte		Watchdog timeout counter

Field Num	Name	Field Location	Field Length	Data Type	Units	Description
21	cmd exe cnt	29	1	UnsignedByte		Number of commands executed
22	cmd rej cnt	30	1	UnsignedByte		Number of commands rejected
23	last opcode	31	1	UnsignedByte		Last executed opcode
24	memop st	32	1	UnsignedByte		Memory Operation Status
25	memdp st	33	1	UnsignedByte		Memory Dump Status
26	max stack	34	1	UnsignedByte		High mark for internal 8051 stack
27	cpu util	35	1	UnsignedByte		Estimate for CPU usage
28	int pending	36	4	UnsignedMSB4		Interrupt pending bits
29	error code	40	1	UnsignedByte		Overall system error code
30	task overrun	41	1	UnsignedByte		Last task that overran the time slice
31	adc status	42	1	UnsignedByte		Status register for the ADC (analog to digital converter)
32	fpe status	43	1	UnsignedByte		FPE (Focal Plane Electronics) status byte
33	fpe p5v v	44	2	UnsignedMSB2	DN	FPE (Focal Plane Electronics) +5V Voltage Monitor
34	fpe p5v i sense	46	2	UnsignedMSB2	DN	FPE (Focal Plane Electronics) +5V Current Monitor
35	fpe p3p3v digital i sense	48	2	UnsignedMSB2	DN	FPE (Focal Plane Electronics) +3.3V Digital Current Monitor
36	fpe p3p3v analog i sense	50	2	UnsignedMSB2	DN	FPE (Focal Plane Electronics) +3.3V Analog Current Monitor
37	fpe p3p3v digital v	52	2	UnsignedMSB2	DN	FPE (Focal Plane Electronics) +3.3V Digital Voltage Monitor
38	fpe p3p3v analog v	54	2	UnsignedMSB2	DN	FPE (Focal Plane Electronics) +3.3V Analog Voltage Monitor
39	fpe p12v v	56	2	UnsignedMSB2	DN	FPE (Focal Plane Electronics) +12V Voltage Monitor
40	fpe n12v v	58	2	UnsignedMSB2	DN	FPE (Focal Plane Electronics) -12V Voltage Monitor
41	fpe p3p3v vref v	60	2	UnsignedMSB2	DN	FPE (Focal Plane Electronics) +3.3V Vref Voltage Monitor
42	fpe p2p5v v	62	2	UnsignedMSB2	DN	FPE (Focal Plane Electronics) +2.5V Vref Voltage Monitor
43	vref hfsc monitor	64	2	UnsignedMSB2	DN	Vref HFSC Monitor
44	adc reserved 0b	66	2	UnsignedMSB2		Reserved
45	adc reserved 0c	68	2	UnsignedMSB2		Reserved
46	adc reserved 0d	70	2	UnsignedMSB2		Reserved

Field Num	Name	Field Location	Field Length	Data Type	Units	Description
47	adc reserved 0e	72	2	UnsignedMSB2		Reserved
48	adc reserved 0f	74	2	UnsignedMSB2		Reserved
49	cdh p12v v	76	2	UnsignedMSB2	DN	C&DH (Command and Data Handling) +12V Voltage Monitor
50	cdh agnd 0x11	78	2	UnsignedMSB2	DN	C&DH (Command and Data Handling) -12V Voltage Monitor
51	cdh p5v v	80	2	UnsignedMSB2	DN	C&DH (Command and Data Handling) +5V Voltage Monitor
52	cdh p3p3v v	82	2	UnsignedMSB2	DN	C&DH (Command and Data Handling) +3.3V Voltage Monitor
53	adc reserved 14	84	2	UnsignedMSB2	DN	C&DH (Command and Data Handling) +1.8V Voltage Monitor
54	cdh p1p5v v	86	2	UnsignedMSB2	DN	C&DH (Command and Data Handling) +1.5V Voltage Monitor
55	cdh fpga temp	88	2	UnsignedMSB2	DN	C&DH (Command and Data Handling) FPGA Temperature Monitor
56	lvps p5v converter temp	90	2	UnsignedMSB2	DN	Low Voltage Power Supply +5V Converter Temperature Monitor
57	lvps_p3p3v_converter_tem p	92	2	UnsignedMSB2	DN	Low Voltage Power Supply +3.3V Converter Temperature Monitor
58	black body temp	94	2	UnsignedMSB2	DN	Black Body 1 Temperature Monitor
59	adc reserved 1a	96	2	UnsignedMSB2		Reserved
60	filament temp	98	2	UnsignedMSB2	DN	Filament Temperature Monitor
61	fpe temp	100	2	UnsignedMSB2	DN	FPE (Focal Plane Electronics) Temperature Monitor
62	fpe asic temp	102	2	UnsignedMSB2	DN	FPE (Focal Plane Electronics) ASIC Temperature Monitor
63	adc reserved 1e	104	2	UnsignedMSB2		Reserved
64	adc reserved 1f	106	2	UnsignedMSB2		Reserved
65	fpa moly a temp	108	2	UnsignedMSB2	DN	Focal Plane Array Molybdenum A Temperature Monitor
66	x2nd stage a temp	110	2	UnsignedMSB2	DN	2nd Stage A Temperature Monitor
67	yolk a temp	112	2	UnsignedMSB2	DN	Yolk A Temperature Monitor
68	x1st stage a temp	114	2	UnsignedMSB2	DN	1st Stage A Temperature Monitor

Field Num	Name	Field Location	Field Length	Data Type	Units	Description
69	foot a temp	116	2	UnsignedMSB2	DN	Foot A Temperature Monitor
70	adc reserved 25	118	2	UnsignedMSB2		Reserved
71	adc reserved 26	120	2	UnsignedMSB2		Reserved
72	adc reserved 27	122	2	UnsignedMSB2		Reserved
73	filament v	124	2	UnsignedMSB2		Filament V
74	filament i	126	2	UnsignedMSB2		Filament I
75	blackbody v	128	2	UnsignedMSB2		Blackbody V
76	blackbody i	130	2	UnsignedMSB2		Blackbody I
77	reserved 2c	132	2	UnsignedMSB2		Blackbody 2 V
78	reserved 2d	134	2	UnsignedMSB2		Blackbody 2 I
79	virtual ground 1 v	136	2	UnsignedMSB2		Virtual Ground 1 V
80	virtual ground 2 v	138	2	UnsignedMSB2		Virtual Ground 2 V
81	rr index	140	1	UnsignedByte		Round Robin Index
82	rr value	141	2	UnsignedMSB2		Round Robin Value
83	scrub mem	143	1	UnsignedByte		Which memory area is currently being scrubbed
84	scrub page	144	2	UnsignedMSB2		4K page currently being scrubbed
85	pwr_on	146	1	UnsignedByte		Indicates that the power enable state of the other OVIRS side
86	fpe comm err	147	1	UnsignedByte		FPE (Focal Plane Electronics) Communication error
87	bad pix	148	1	UnsignedByte		Bad pixel enabled
88	test buff	149	1	UnsignedByte		Which SCI buffer should TEST_GO process
89	test go	150	1	UnsignedByte		Force FPGA to process SCI Buffer
90	sup pix	151	1	UnsignedByte		Super Pixel enabled
91	cds mode	152	1	UnsignedByte		Correlated Double Sampling mode enabled
92	xface	153	1	UnsignedByte		FPE (Focal Plane Electronics) high speed interface turned on
93	spare2	154	1	UnsignedByte		Spare field
94	fpe dead	155	1	UnsignedByte		Flag indicating the FPE alive time has stopped
95	bad pix parity	156	1	UnsignedByte		Flag indicating a bad pixel parity error has occurred
96	bad pix reset	157	1	UnsignedByte		Reset the bad pixel pointer
97	task timestamp	158	4	UnsignedMSB4		Last timestamp of task that overran
98	task index	162	1	UnsignedByte		Index of last task that overran

Field Num	Name	Field Location	Field Length	Data Type	Units	Description
99	task addr	163	2	UnsignedMSB2		Address of last task that overran
100	task count	165	1	UnsignedByte		Counter for number of task overruns
101	fpe fsw error	166	2	UnsignedMSB2		FPE (Focal Plane Electronics) Flight Software Error
102	fpe status 1	168	2	UnsignedMSB2		FPE (Focal Plane Electronics) Status 1
103	fpe status 2	170	2	UnsignedMSB2		FPE (Focal Plane Electronics) Status 2
104	fpe cmdvldcntr	172	2	UnsignedMSB2		FPE (Focal Plane Electronics) command valid counter
105	fpe cmdrjctcntr	174	2	UnsignedMSB2		FPE (Focal Plane Electronics) command rejected counter
106	fpe cmdignrcntr	176	2	UnsignedMSB2		FPE (Focal Plane Electronics) command ignored counter
107	fpe cmd	178	4	UnsignedMSB4		FPE (Focal Plane Electronics) current command (32-bit)
108	fpe lstcmd	182	4	UnsignedMSB4		FPE (Focal Plane Electronics) last command
109	fpe if write	186	2	UnsignedMSB2		FPE (Focal Plane Electronics) interface write status
110	fpe frametimerollover	188	2	UnsignedMSB2		FPE (Focal Plane Electronics) frame time rollover
111	fpe frametimemarker	190	2	UnsignedMSB2		FPE (Focal Plane Electronics) frame time marker
112	fpe dropframes	192	2	UnsignedMSB2		FPE (Focal Plane Electronics) current drop frame
113	fpe mismatch	194	1	UnsignedByte		Indicates if CDH and FPE have consistent configurations
114	scrub addr sram	195	4	UnsignedMSB4		SRAM scrub address
115	scrub addr mram	199	4	UnsignedMSB4		MRAM scrub address
116	fpe offset	203	2	UnsignedMSB2		FPE (Focal Plane Electronics) offset for read values
117	fpe crc line	205	2	UnsignedMSB2		Line number for last FPE CRC (cyclic redundancy check) error
118	spare3	207	1	UnsignedByte		Reserved
119	fpe crc frame	208	1	UnsignedByte		Frame number for last FPE CRC (cyclic redundancy check) error
120	max event queue	209	1	UnsignedByte		Maximum event queue
121	max tlm queue	210	1	UnsignedByte		Maximum Telemetry queue
122	fpe 5v current	211	2	UnsignedMSB2	DN	FPE 5V Current
123	fpe 3va current	213	2	UnsignedMSB2	DN	FPE 3VA Current
124	fpe 3vd current	215	2	UnsignedMSB2	DN	FPE 3VD Current
125	fpe 3vm current	217	2	UnsignedMSB2	DN	FPE 3VM Current

Field Num	Name	Field Location	Field Length	Data Type	Units	Description
126	reserved	219	2	UnsignedMSB2		Reserved

5.2.4 OVIRS L1 HOUSEKEEPING

The OVIRS L1 housekeeping data product is a 125-field binary table with a total width of 315 bytes. This is a translation of the OVIRS L0 housekeeping data product and will follow the L0 cadence (generally 1 per second, 1 table row per measurement). PDS data products group the hk observations either per science sequence or per Earth day to make the hk product file sizes manageable. All fields ending in an “_x” have been converted from DN to physical units according to the by attribute engineering conversions given in the “OVIRS Engineering Conversions Document” in the bundle document collection.

Table 5-5. OVIRS L1 Housekeeping Data Product

Field Num	Name	Field Location	Field Length	Data Type	Units	Description
1	idp_sync	0	4	UnsignedMSB4		Synchronization Pattern
2	idp_ccsds_pkt_len	4	2	UnsignedMSB2		Number of bytes following this field - 1
3	idp_ccsds_timestamp	6	4	UnsignedMSB4		Timestamp (Mission Elapsed Time coarse counter)
4	uart_status	10	1	UnsignedByte		Status register for UART (universal asynchronous receiver-transmitter)
5	wdt_count	11	1	UnsignedByte		Watchdog timeout counter
6	cmd_exe_cnt	12	1	UnsignedByte		Number of commands executed
7	cmd_rej_cnt	13	1	UnsignedByte		Number of commands rejected
8	last_opcode	14	1	UnsignedByte		Last executed opcode
9	max_stack	15	1	UnsignedByte		High mark for internal 8051 stack
10	cpu_util	16	1	UnsignedByte		Estimate for CPU usage
11	int_pending	17	4	UnsignedMSB4		Interrupt pending bits
12	error_code	21	1	UnsignedByte		Overall system error code
13	task_overrun	22	1	UnsignedByte		Last task that overran the time slice
14	adc_status	23	1	UnsignedByte		Status register for the ADC (Analog to Digital Converter)

Field Num	Name	Field Location	Field Length	Data Type	Units	Description
15	fpe status	24	1	UnsignedByte		FPE (Focal Plane Electronics) status byte
16	fpe p5v v x	25	4	IEEE754MSBSSingle	V	FPE (Focal Plane Electronics) +5V Voltage Monitor
17	fpe p5v i sense x	29	4	IEEE754MSBSSingle	A	FPE (Focal Plane Electronics) +5V Current Monitor
18	fpe p3p3v digital i sense x	33	4	IEEE754MSBSSingle	A	FPE (Focal Plane Electronics) +3.3V Digital Current Monitor
19	fpe p3p3v analog i sense x	37	4	IEEE754MSBSSingle	A	FPE (Focal Plane Electronics) +3.3V Analog Current Monitor
20	fpe p3p3v digital v x	41	4	IEEE754MSBSSingle	V	FPE (Focal Plane Electronics) +3.3V Digital Voltage Monitor
21	fpe p3p3v analog v x	45	4	IEEE754MSBSSingle	V	FPE (Focal Plane Electronics) +3.3V Analog Voltage Monitor
22	fpe p12v v x	49	4	IEEE754MSBSSingle	V	FPE (Focal Plane Electronics) +12V Voltage Monitor
23	fpe n12v v x	53	4	IEEE754MSBSSingle	V	FPE (Focal Plane Electronics) -12V Voltage Monitor
24	fpe p3p3v vref v x	57	4	IEEE754MSBSSingle	V	FPE (Focal Plane Electronics) +3.3V Vref Voltage Monitor
25	fpe p2p5v v x	61	4	IEEE754MSBSSingle	V	FPE (Focal Plane Electronics) +2.5V Voltage Monitor
26	vref hfsc monitor x	65	4	IEEE754MSBSSingle	V	Vref HFSC Monitor
27	adc reserved 0b x	69	4	IEEE754MSBSSingle		Reserved
28	adc reserved 0c x	73	4	IEEE754MSBSSingle		Reserved
29	adc reserved 0d x	77	4	IEEE754MSBSSingle		Reserved
30	adc reserved 0e x	81	4	IEEE754MSBSSingle		Reserved
31	adc reserved 0f x	85	4	IEEE754MSBSSingle		Reserved
32	cdh p12v v x	89	4	IEEE754MSBSSingle	V	C&DH (Command and Data Handling) +12V Voltage Monitor
33	cdh agnd 0x11 x	93	4	IEEE754MSBSSingle	V	C&DH (Command and Data Handling) -12V Voltage Monitor
34	cdh p5v v x	97	4	IEEE754MSBSSingle	V	C&DH (Command and Data Handling) +5V Voltage Monitor
35	cdh p3p3v v x	101	4	IEEE754MSBSSingle	V	C&DH (Command and Data Handling) +3.3V Voltage Monitor
36	adc reserved 14 x	105	4	IEEE754MSBSSingle	V	C&DH (Command and Data Handling) +1.8V Voltage Monitor

Field Num	Name	Field Location	Field Length	Data Type	Units	Description
37	cdh_p1p5v v x	109	4	IEEE754MSBSingle	V	C&DH (Command and Data Handling) +1.5V Voltage Monitor
38	cdh_fpga temp x	113	4	IEEE754MSBSingle	degC	C&DH (Command and Data Handling) FPGA Temperature Monitor
39	lvps_p5v converter temp x	117	4	IEEE754MSBSingle	degC	Low Voltage Power Supply +5V Converter Temperature Monitor
40	lvps_p3p3v_converter_temp_x	121	4	IEEE754MSBSingle	degC	Low Voltage Power Supply +3.3V Converter Temperature Monitor
41	black body temp x	125	4	IEEE754MSBSingle	degC	Black Body 1 Temperature Monitor
42	adc reserved 1a x	129	4	IEEE754MSBSingle	degC	Reserved
43	filament temp x	133	4	IEEE754MSBSingle	degC	Filament Temperature Monitor
44	fpe temp x	137	4	IEEE754MSBSingle	degC	FPE (Focal Plane Electronics) Temperature Monitor
45	fpe asic temp x	141	4	IEEE754MSBSingle	degC	FPE (Focal Plane Electronics) ASIC Temperature Monitor
46	adc reserved 1e x	145	4	IEEE754MSBSingle		Reserved
47	adc reserved 1f x	149	4	IEEE754MSBSingle		Reserved
48	fpa moly a temp x	153	4	IEEE754MSBSingle	degC	Focal Plane Array Molybdenum A Temperature Monitor
49	x2nd stage a temp x	157	4	IEEE754MSBSingle	degC	2nd Stage A Temperature Monitor
50	yolk a temp x	161	4	IEEE754MSBSingle	degC	Yolk A Temperature Monitor
51	x1st stage a temp x	165	4	IEEE754MSBSingle	degC	1st Stage A Temperature Monitor
52	foot a temp x	169	4	IEEE754MSBSingle	degC	Foot A Temperature Monitor
53	adc reserved 25 x	173	4	IEEE754MSBSingle		Reserved
54	adc reserved 26 x	177	4	IEEE754MSBSingle		Reserved
55	adc reserved 27 x	181	4	IEEE754MSBSingle		Reserved
56	filament v x	185	4	IEEE754MSBSingle	V	Filament V
57	filament i x	189	4	IEEE754MSBSingle	A	Filament I
58	blackbody v x	193	4	IEEE754MSBSingle	V	Blackbody 1 V
59	blackbody i x	197	4	IEEE754MSBSingle	A	Blackbody 1 I
60	reserved 2c x	201	4	IEEE754MSBSingle	V	Blackbody 2 V
61	reserved 2d x	205	4	IEEE754MSBSingle	A	Blackbody 2 I
62	virtual ground 1 v x	209	4	IEEE754MSBSingle	V	Virtual Ground 1 V
63	virtual ground 2 v x	213	4	IEEE754MSBSingle	V	Virtual Ground 2 V

Field Num	Name	Field Location	Field Length	Data Type	Units	Description
64	rr index	217	1	UnsignedByte		Round Robin Index
65	rr value	218	2	UnsignedMSB2		Round Robin Value
66	task timestamp	220	4	UnsignedMSB4		Last timestamp of task that overran
67	task index	224	1	UnsignedByte		Index of last task that overran
68	task addr	225	2	UnsignedMSB2		Address of last task that overran
69	task count	227	1	UnsignedByte		Counter for number of task overruns
70	fpe fsw error	228	2	UnsignedMSB2		FPE (Focal Plane Electronics) Flight Software Error
71	fpe status 1	230	2	UnsignedMSB2		FPE (Focal Plane Electronics) Status 1
72	fpe status 2	232	2	UnsignedMSB2		FPE (Focal Plane Electronics) Status 2
73	fpe cmdvldcntr	234	2	UnsignedMSB2		FPE (Focal Plane Electronics) command valid counter
74	fpe cmdrjctcntr	236	2	UnsignedMSB2		FPE (Focal Plane Electronics) command rejected counter
75	fpe cmdignrcntr	238	2	UnsignedMSB2		FPE (Focal Plane Electronics) command ignored counter
76	fpe cmd	240	4	UnsignedMSB4		FPE (Focal Plane Electronics) current command (32-bit)
77	fpe lstcmd	244	4	UnsignedMSB4		FPE (Focal Plane Electronics) last command
78	fpe if write	248	2	UnsignedMSB2		FPE (Focal Plane Electronics) interface write status
79	fpe frametimerollover	250	2	UnsignedMSB2		FPE (Focal Plane Electronics) frame time rollover
80	fpe frametimemarker	252	2	UnsignedMSB2		FPE (Focal Plane Electronics) frame time marker
81	fpe dropframes	254	2	UnsignedMSB2		FPE (Focal Plane Electronics) current drop frame
82	fpe mismatch	256	1	UnsignedByte		Indicates if CDH and FPE (Focal Plane Electronics) have consistent configurations
83	scrub_addr_sram	257	4	UnsignedMSB4		SRAM scrub address
84	scrub_addr_mram	261	4	UnsignedMSB4		MRAM scrub address
85	fpe offset	265	2	UnsignedMSB2		FPE (Focal Plane Electronics) offset for read values
86	fpe crc line	267	2	UnsignedMSB2		Line number for last FPE (Focal Plane Electronics) CRC (cyclic redundancy check) error
87	max_event_queue	269	1	UnsignedByte		Maximum event queue
88	max_tlm_queue	270	1	UnsignedByte		Maximum Telemetry queue
89	fpe 5v current	271	2	UnsignedMSB2		FPE (Focal Plane Electronics) 5V Current
90	fpe 3va current	273	2	UnsignedMSB2		FPE (Focal Plane Electronics) 3VA Current

Field Num	Name	Field Location	Field Length	Data Type	Units	Description
91	fpe 3vd current	275	2	UnsignedMSB2		FPE (Focal Plane Electronics) 3VD Current
92	fpe 3vm current	277	2	UnsignedMSB2		FPE (Focal Plane Electronics) 3VM Current
93	idp csds ver	279	1	UnsignedByte		CCSDS Packet Version
94	idp csds type	280	1	UnsignedByte		CCSDS Packet Type
95	idp csds sec flag	281	1	UnsignedByte		CCSDS Secondary Header Flag
96	idp csds apid	282	2	UnsignedMSB2		Packet ID, Data Product Identifier
97	idp csds grp flags	284	1	UnsignedByte		Grouping flags
98	idp csds seq cnt	285	2	UnsignedMSB2		Number of times this packet has been sent
99	udp ip rcv cnt	287	1	UnsignedByte		Number of UDP/IP packets received
100	udp ip err cnt	288	1	UnsignedByte		Number of invalid UDP/IP packets received
101	sc time stat cnt	289	1	UnsignedByte		Number of SC Time and Status Messages received
102	pps cnt	290	1	UnsignedByte		Number of PPS (pulse per second) pulses received
103	edac sram snl st	291	1	UnsignedByte		SRAM single-bit error status
104	edac sram dbl st	292	1	UnsignedByte		SRAM multi-bit error status
105	edac mram snl st	293	1	UnsignedByte		MRAM single-bit error status
106	edac mram dbl st	294	1	UnsignedByte		MRAM multi-bit error status
107	op mode	295	1	UnsignedByte		Software Mode
108	memop st	296	1	UnsignedByte		Memory Operation Status
109	memdp st	297	1	UnsignedByte		Memory Dump Status
110	scrub mem	298	1	UnsignedByte		Which memory area is currently being scrubbed
111	scrub page	299	2	UnsignedMSB2		4K page currently being scrubbed
112	pwr on	301	1	UnsignedByte		Indicates that the power enable state of the other OVIRS side
113	fpe comm err	302	1	UnsignedByte		FPE (Focal Plane Electronics) Communications error
114	bad pix	303	1	UnsignedByte		Bad pixel enabled
115	test buff	304	1	UnsignedByte		Which SCI buffer should TEST GO process
116	test go	305	1	UnsignedByte		Force FPGA to process SCI Buffer
117	sup pix	306	1	UnsignedByte		Super Pixel enabled
118	cds mode	307	1	UnsignedByte		Correlated Double Sampling mode enabled
119	xface	308	1	UnsignedByte		FPE (Focal Plane Electronics) high speed interface turned on
120	spare2	309	1	UnsignedByte		Spare field

Field Num	Name	Field Location	Field Length	Data Type	Units	Description
121	fpe dead	310	1	UnsignedByte		Flag indicating the FPE (Focal Plane Electronics) alive time has stopped
122	bad pix parity	311	1	UnsignedByte		Flag indicating a bad pixel parity error has occurred
123	bad pix reset	312	1	UnsignedByte		Reset the bad pixel pointer
124	spare3	313	1	UnsignedByte		Reserved
125	fpe_crc_frame	314	1	UnsignedByte		Frame number for last FPE (Focal Plane Electronics) CRC (cyclic redundancy check) error

5.3 Label and Header Descriptions

Each OVIRS data product has an associated detached PDS4 compliant XML label. This label contains enough information for a user to understand and interpret the data product and the circumstances of data collection. See Section 7.4 for example labels for all OVIRS data products.

As all OVIRS science data products are produced in FITS format, they all contain an attached FITS header. FITS header information includes mission, timing, geometry and observation specific information. The information contained in the FITS header is duplicated in the detached PDS XML label.

6 Applicable Software

6.1 Utility Programs

At the current time, the OSIRIS-REX project has no plans to release any mission specific utility programs. OVIRS science data products are formatted as FITS files. Standard FITS utilities can be used to view or manipulate these products. See http://fits.gsfc.nasa.gov/fits_utility.html for a summary of FITS utilities.

6.2 Applicable PDS Software Tools

The PDS supplies a number of software tools that can be used in conjunction with PDS data products. Please refer to the PDS4 software website (<http://pds.nasa.gov/pds4/software/index.shtml>) for additional information on these tools.

6.3 Software Distribution and Update Procedures

As the OSIRIS-REx project will not be providing software, this section is not applicable.

7 Appendix

7.1 Acronyms

ADC	Analog to Digital Converter
CDS	Correlated Double Sampling
DN	Digital Number
DSN	Deep Space Network
ET	Ephemeris Time
FEDS	Front End Data System
FITS	Flexible Image Transport System
FOV	Field of View
FPE	Focal Plane Electronics
HK	Housekeeping
LM	Lockheed Martin
LVF	Linear Variable Filter
MEB	Main Electronics Box
MSA	Mission Support Area
OAP	Off-Axis Parabolic
OVIRS	OSIRIS-REx Visible and Near InfraRed Spectrometer
PDS	Planetary Data System
ROI	Regions of Interest
SBN	Small Bodies Node
SCLK	Spacecraft Clock
SIS	Software Interface Specification
SNR	Signal to Noise Ratio
SPOC	Science Operations and Processing Center
UTC	Coordinated Universal Time

7.2 References

- [1] Reuter et al. 2008 Space Sci. Rev. 140, 129-154.
- [2] Campins et al. 2010, Nature 464, 1320-1321.
- [3] Rivkin and Emory 2010, Nature 464, 1322-1323.
- [4] Simon et al. 2018, Remote Sensing 10, 1486; <https://doi.org/10.3390/rs10091486>

7.3 Definitions of Data Processing Levels

Table 7-1 shows the comparison of OSIRIS-REx, NASA and CODMAC data processing levels. The OSIRIS-REx team generally uses descriptions when classifying data rather than data levels.

Table 7-1. Data Processing Levels

OSIRIS-REx	NASA	CODMAC	Description
	Packet data	Raw - Level 1	Telemetry data stream as received at the ground station, with science and engineering data embedded.
Level 0 - Raw	Level 0	Edited - Level 2	Instrument science data (e.g., raw voltages, counts) at full resolution, time ordered, with duplicates and transmission errors removed.
Level 1- Uncalibrated	Level 1A	Calibrated - Level 3	NASA Level 0 data that have been located in space and may have been transformed (e.g., corrected) and packaged with needed ancillary and auxiliary data.
Level 2 - Calibrated	Level 1B	Resampled - Level 4	Transformed (e.g., resampled, remapped, calibrated) values of the instrument measurements (e.g., radiances, magnetic field strength).
Level 3 - Processed	Level 1C	Derived - Level 5	NASA Level 1A or 1B data that have been resampled and mapped onto uniform space-time grids. The data are calibrated (i.e., radiometrically corrected) and may have additional corrections applied (e.g., terrain correction).
Level 4 - Derived	Level 2	Derived - Level 5	Geophysical parameters, generally derived from Level 1 data, and located in space and time commensurate with instrument location, pointing, and sampling.
Level 4 - Derived	Level 3	Derived - Level 5	Geophysical parameters mapped onto uniform space-time grids.

OSIRIS-REx Data Product Level Definitions	
Level	Definition
OREx Level 0	<i>Telemetry.</i> Raw instrument data reconstructed from telemetry with header and ancillary information appended. Appended header and ancillary data are data necessary for further processing.
OREx Level 1	<i>Uncalibrated.</i> Data in one of the fundamental structures.
OREx Level 2	<i>Calibrated.</i> Data in units proportional to physical units. Since PDS allows offsets and scaling factors in its array and table structures, this would be the minimum level capable of satisfying the “in physical units” requirement.
OREx Level 3	<i>Irreversibly processed.</i> Higher-level products from a single source that cannot be losslessly converted back to the lower-level products from which they were derived. These might also satisfy the “in physical units” requirement.
OREx Level 4	<i>Derived data.</i> Products created by combining data from more than one source (instrument, observer, etc.).

7.4 Example PDS Labels

Example labels can be found in the OVIRS bundle document collection in a sub-directory named “example_labels”. There are example labels for each type of OVIRS data product.